

NOTICE - PROPRIETARY INFORMATION

THIS DOCUMENT CONTAINS PROPRIETARY INFORMATION AND SHALL NOT BE REPRODUCED, MADE PUBLIC, OR DISCLOSED TO OTHERS WITHOUT THE WRITTEN PERMISSION OF MCPHERSON INC.

- 1) SLIDE P/N 207-209 BACK-SHELL OVER CABLE.
- 2) DISASSEMBLE GROMMET FROM MOTOR. ISOLATE VIOLET WIRE & CUT FROM CABLE JACKET.
- 3) REMOVE VIOLET WIRE FROM MOTOR AND REASSEMBLE GROMMET TO MOTORCUT VIOLET WIRE AT CONNECTOR END.
- 4) ATTACH P/N 432-1124 TERMINAL TO EACH WIRE EXCEPT ORANGE, BLUE, YELLOW, & BROWN WIRES.
- 5) CONNECT BLUE & YELLOW AND ORANGE & BROWN TOGETHER AS SHOWN. APPLY SHRINK TUBING OVER CONNECTIONS.
- 6) INSTALL WIRES WITH 432-1124 TERMINALS INTO ASSIGNED POSITIONS ON MOTOR CONNECTOR.
- 7) ASSEMBLE P/N 207-209 BACK-SHELL TO REAR OF CONNECTOR (NOT SHOWN).

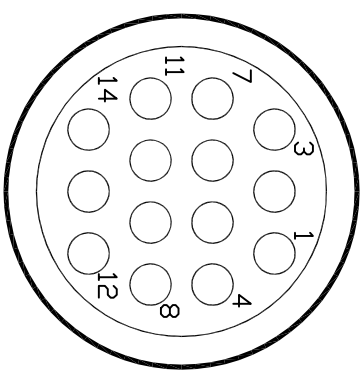

REFERENCE
(WIRE SIDE)

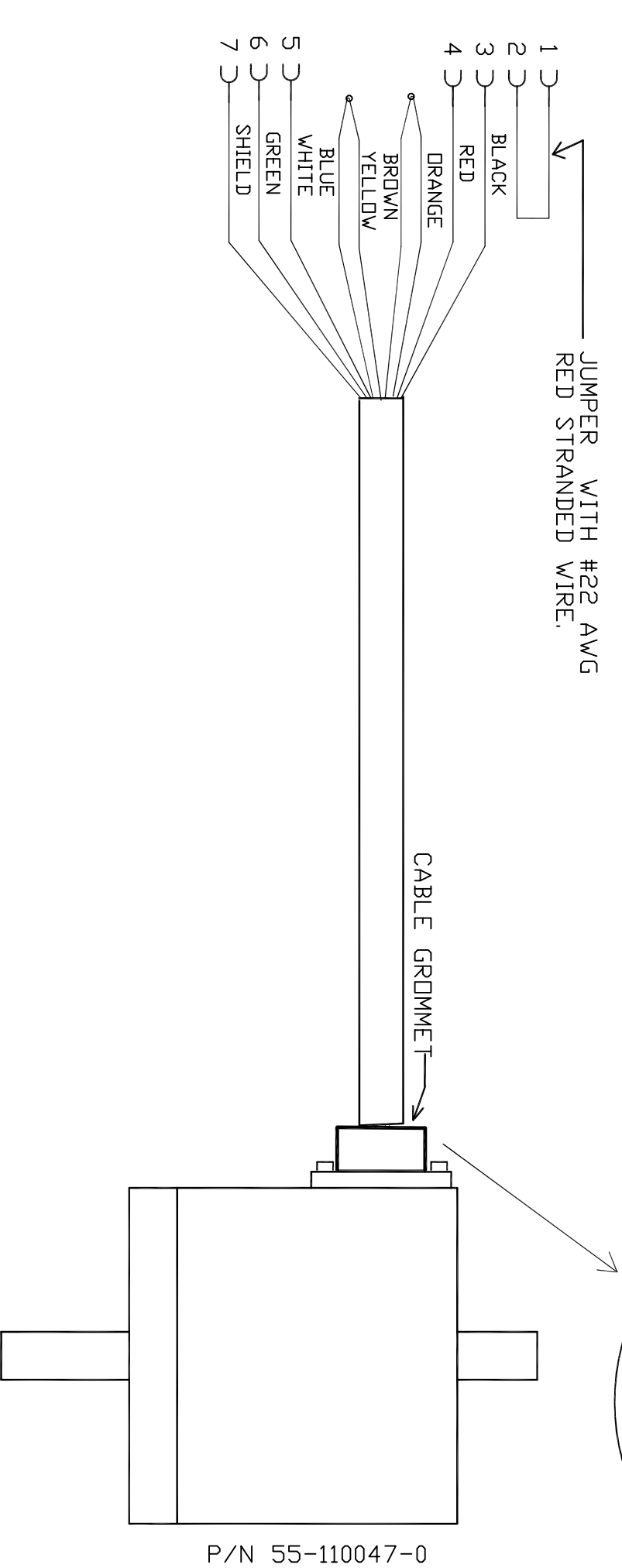
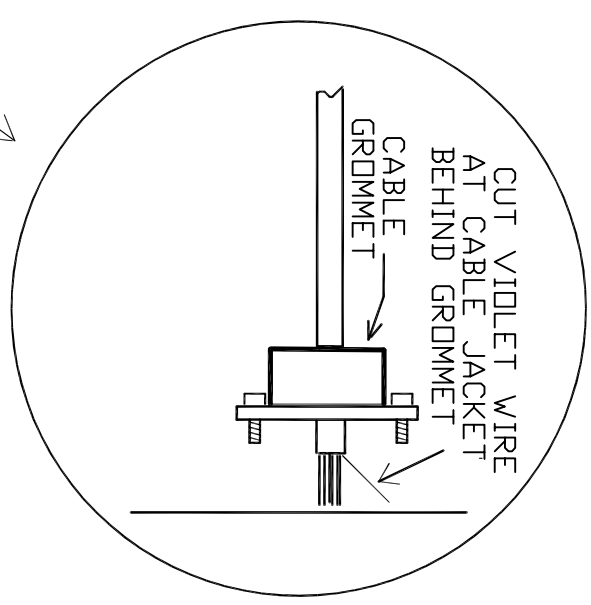
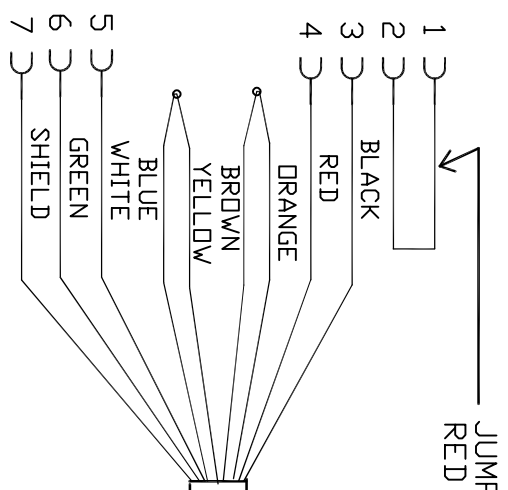

REV.	DESCRIPTION	NAME	DATE	MODEL NO.
A	INITIAL RELEASE	SRH	4/24/01	PART NO.
B	CHNG'D TO NEW MOTOR # 55-110047-0 (WITH 10 FT CABLE)	SRH	11/17/09	BLOCK DIAG.

MCPHERSON INC.
 7A STUARTROAD CHELMSFORD,MA 01824 TEL (978) 256-4512

DRAWING TITLE
STANDARD 789A-3 MOTOR & CABLE ASSEMBLY

REV.	DESCRIPTION	DATE	BY	CHECKED
B			SRH	4/24/01

SIZE **B** DRAWING NO. **135-104194** SHEET OF **B** REV. **B**