

Progress of the VUV setup

Casimir van der Post

 **TU**Delft

Nik|hef

Why investigate the optical properties, and what makes it complex

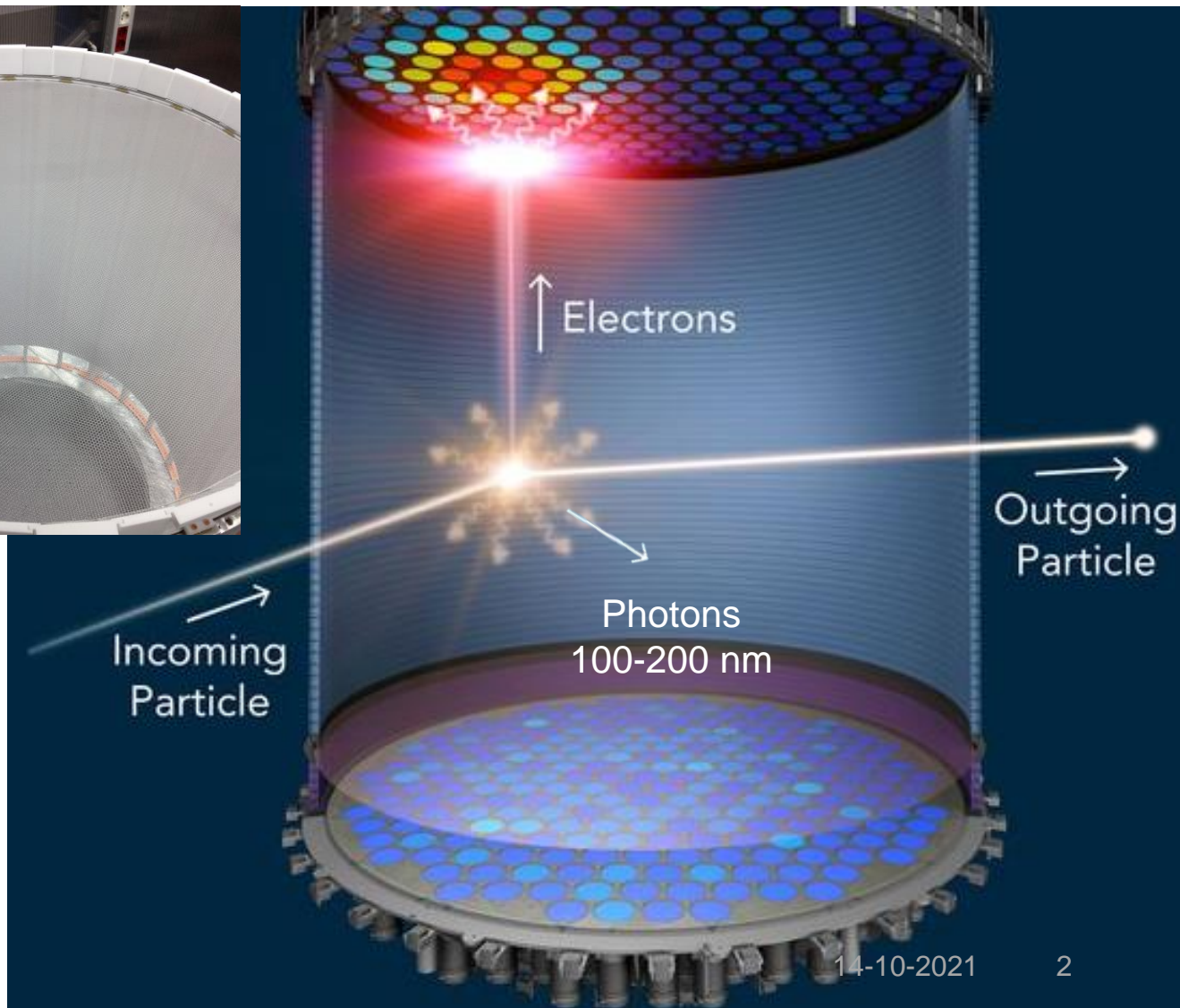
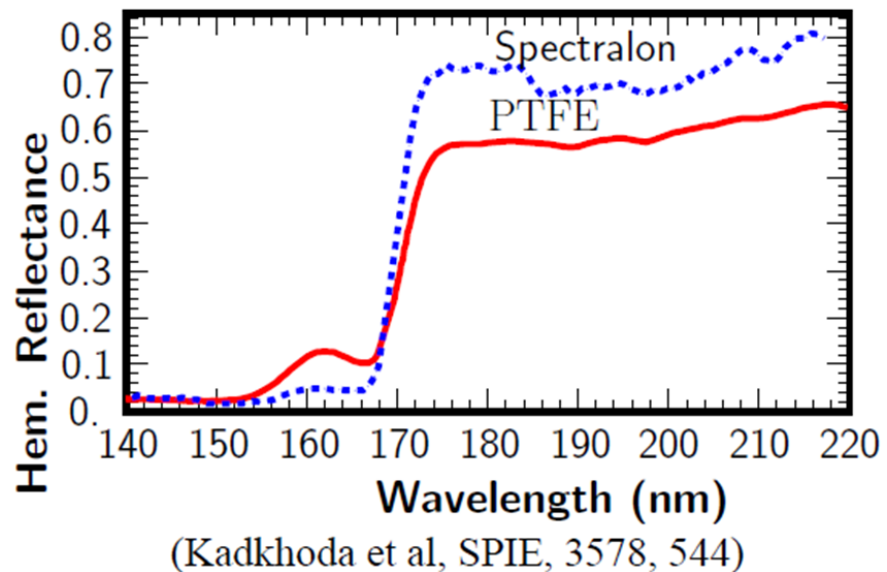

What the design looks like

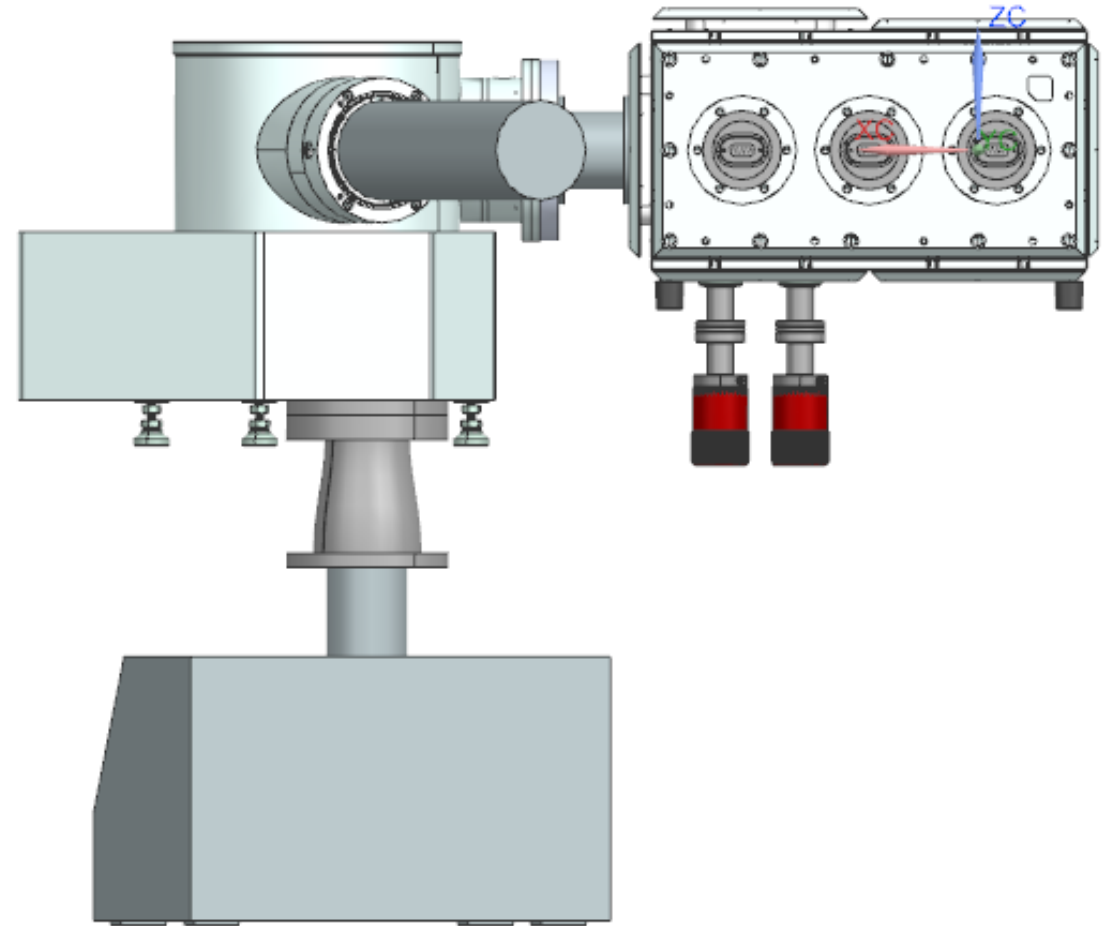
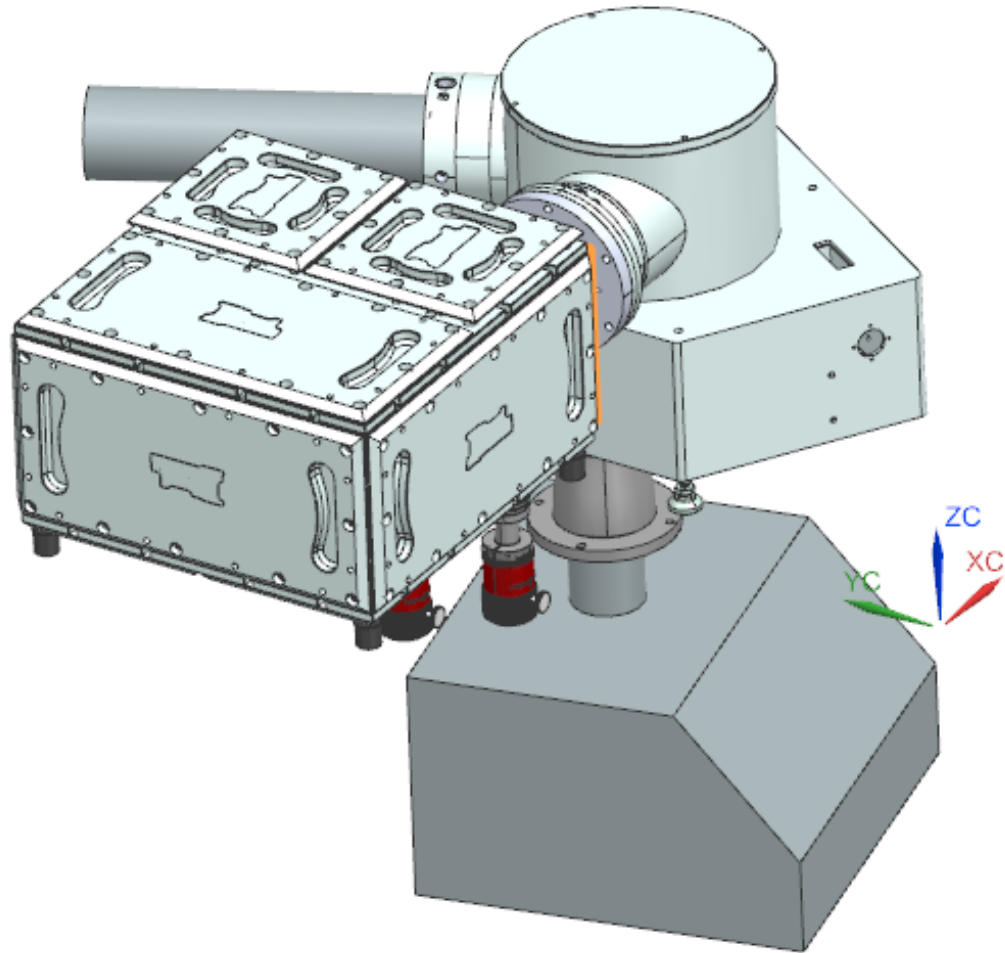

CAD drawing of the complete VUV experiment with the modular table

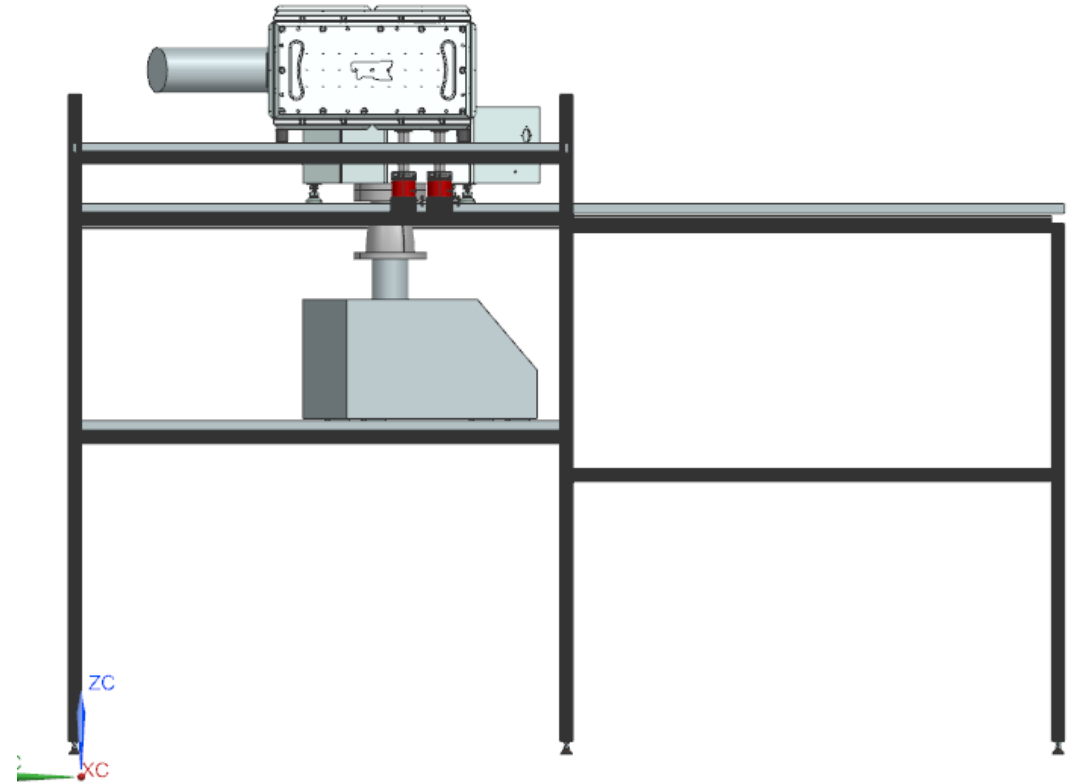
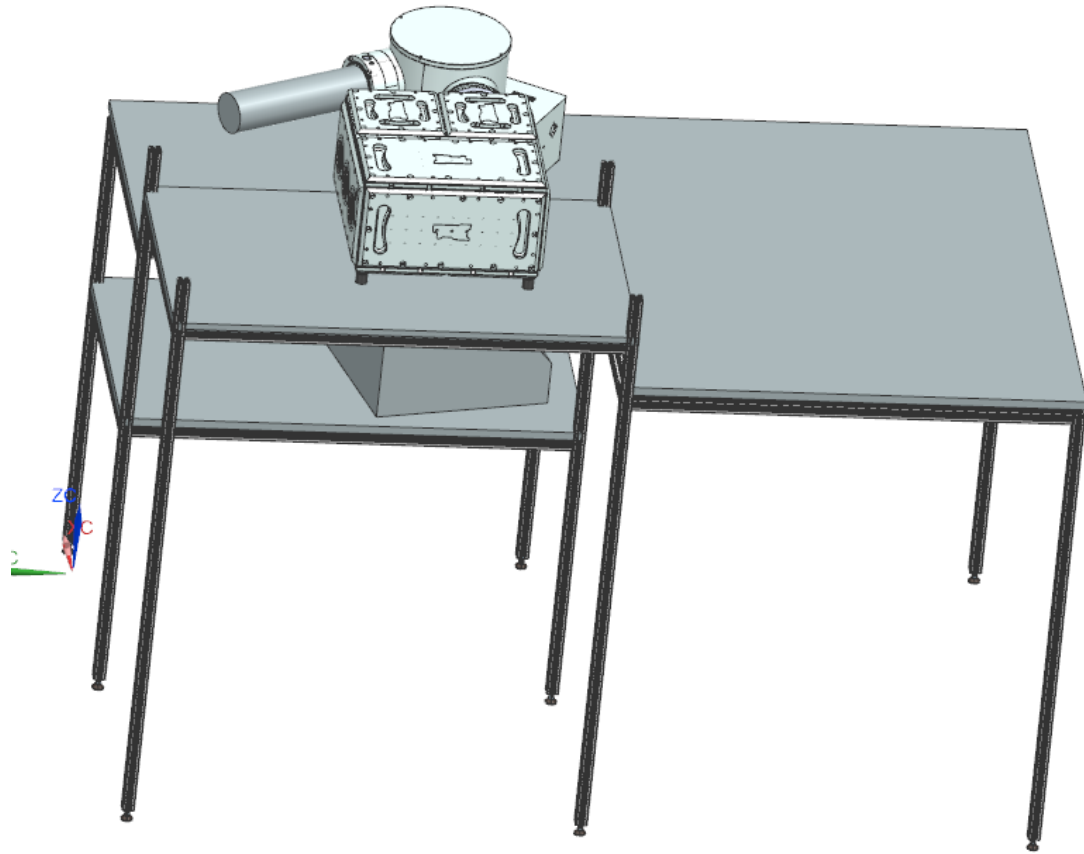

Presentation outline

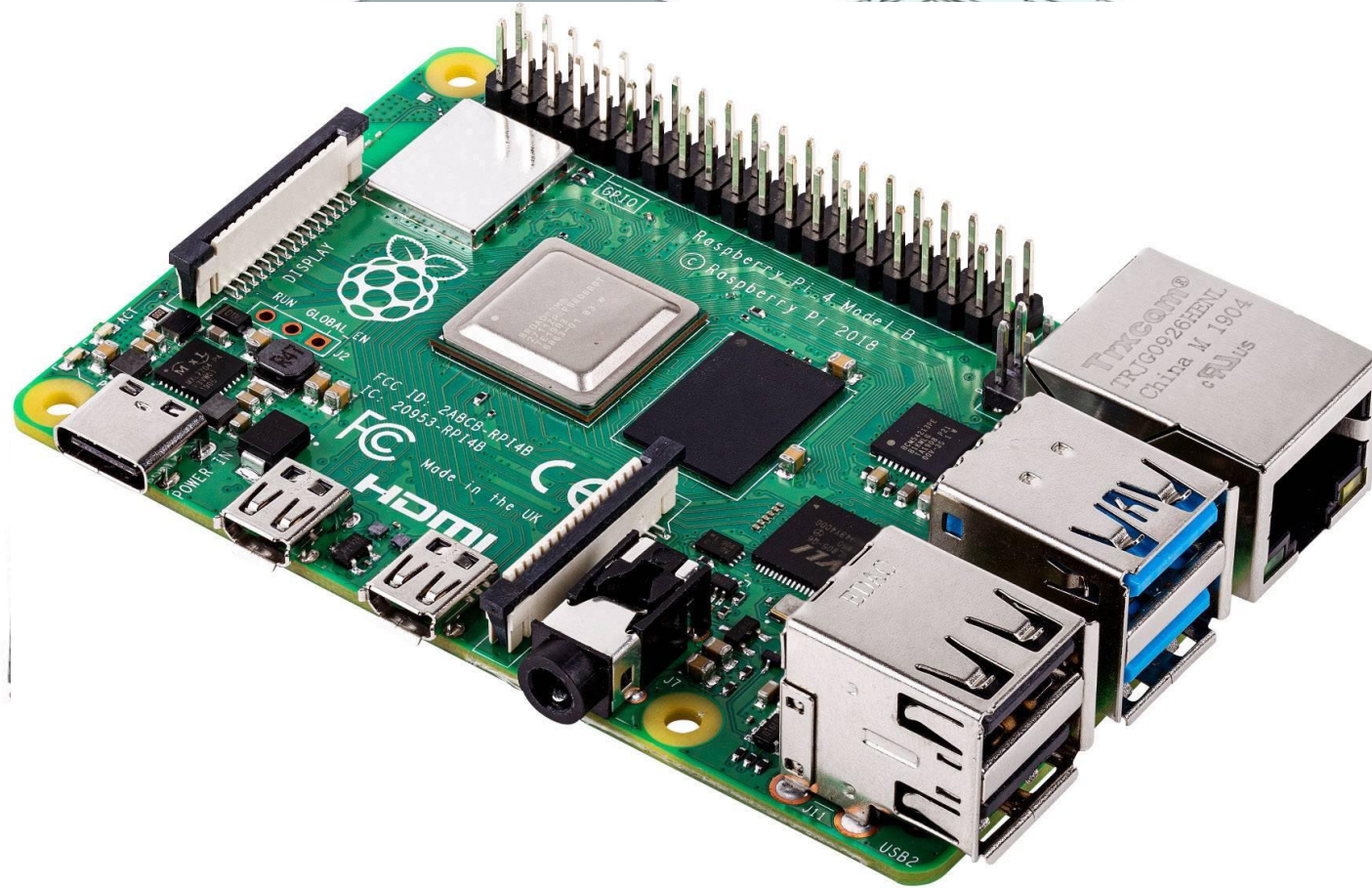

The deuterium lamp (Hamamatsu L15094)

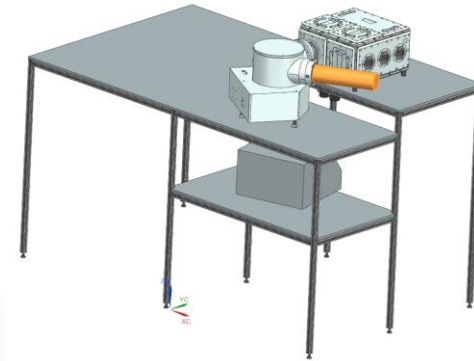
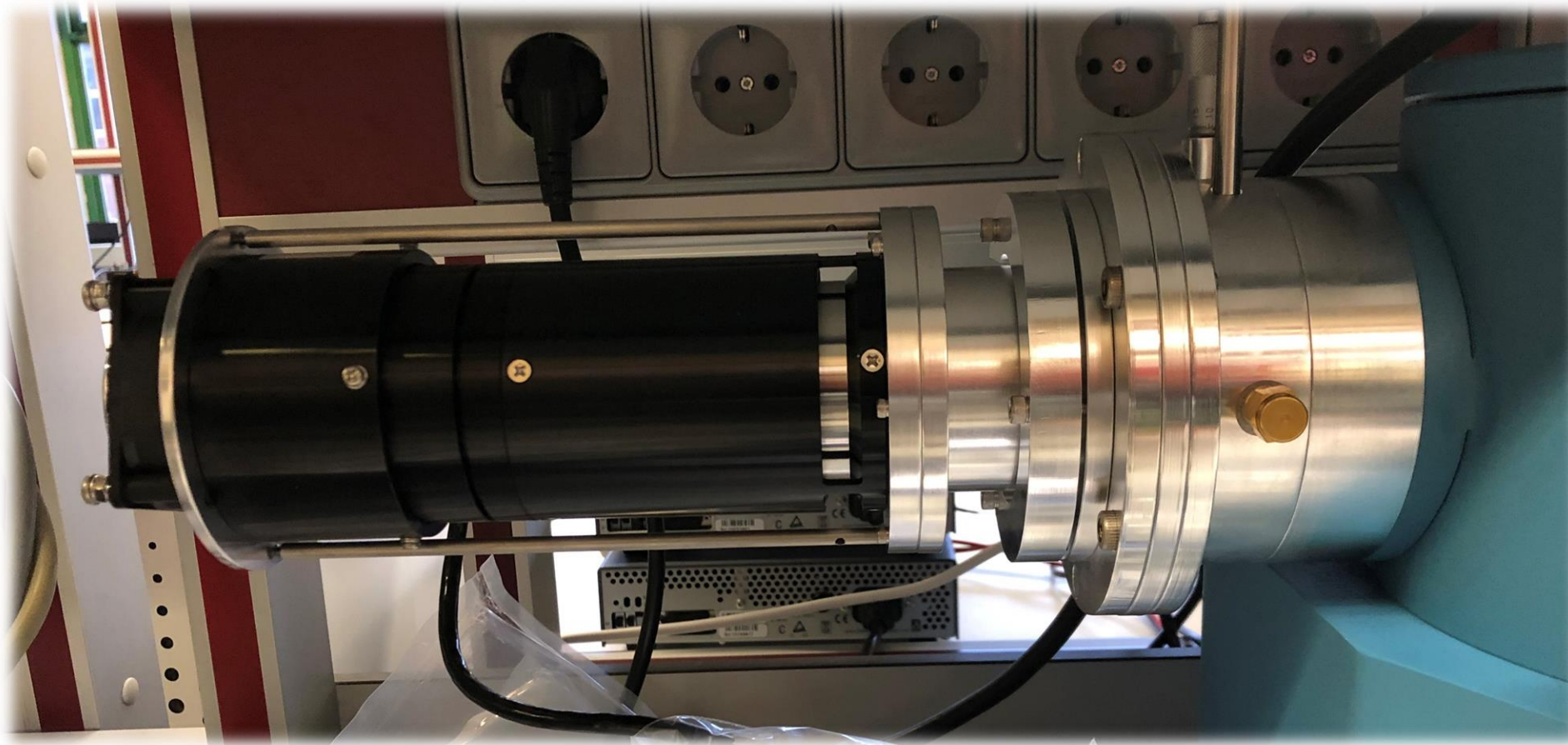

The Monochromator (McPherson 234-302)

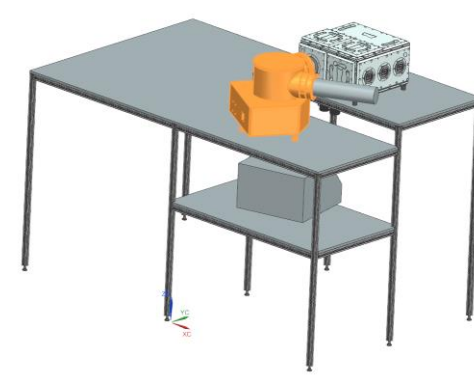
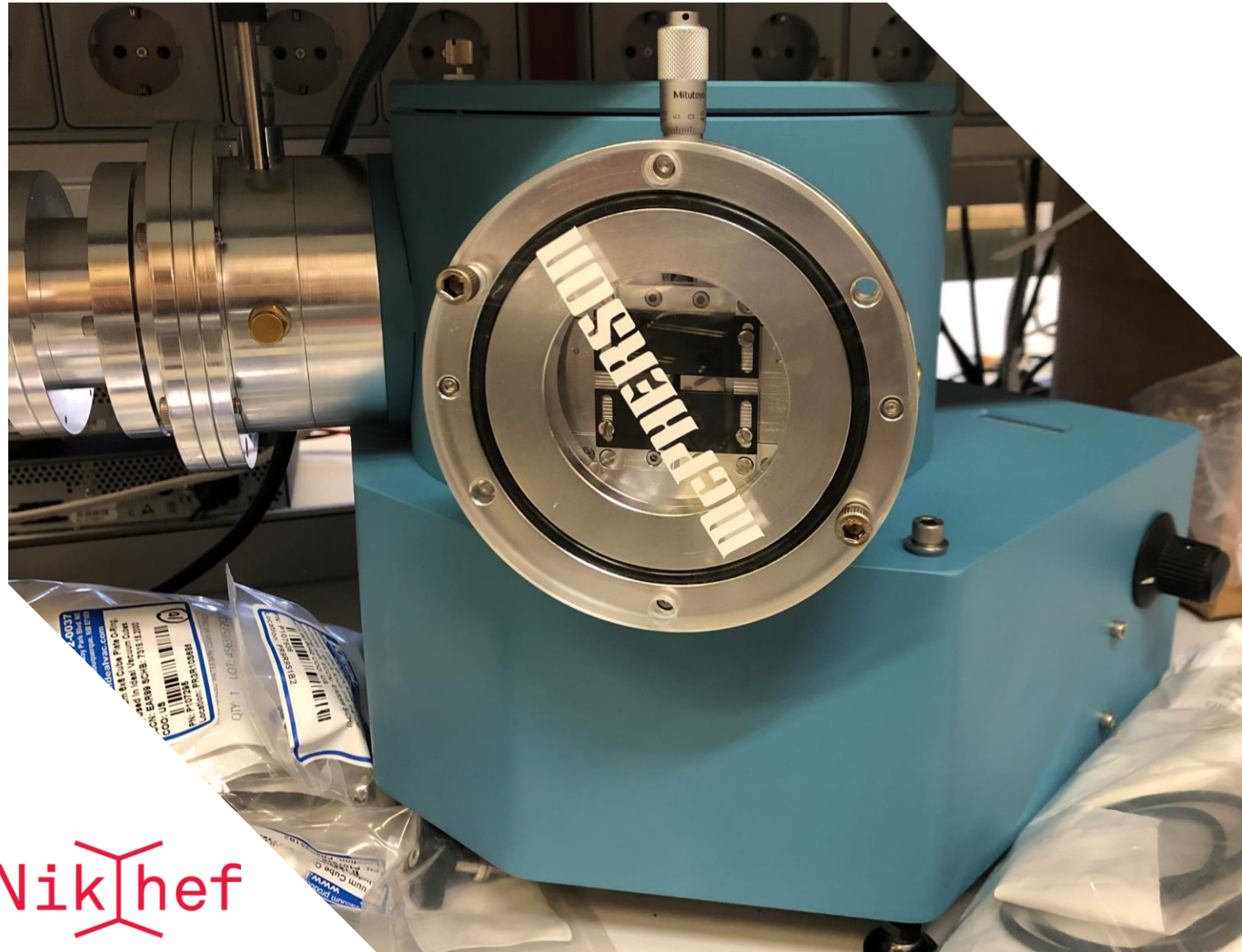

Vacuum station Pfeiffer HiCube 80 Eco

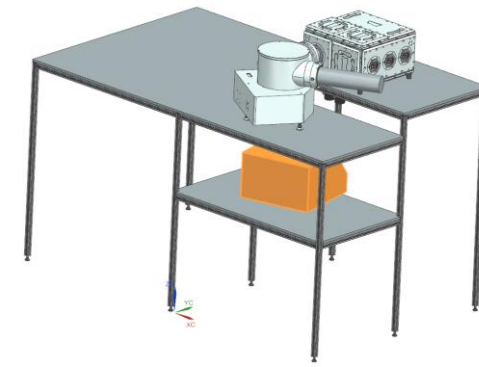

The Vacuum Chamber

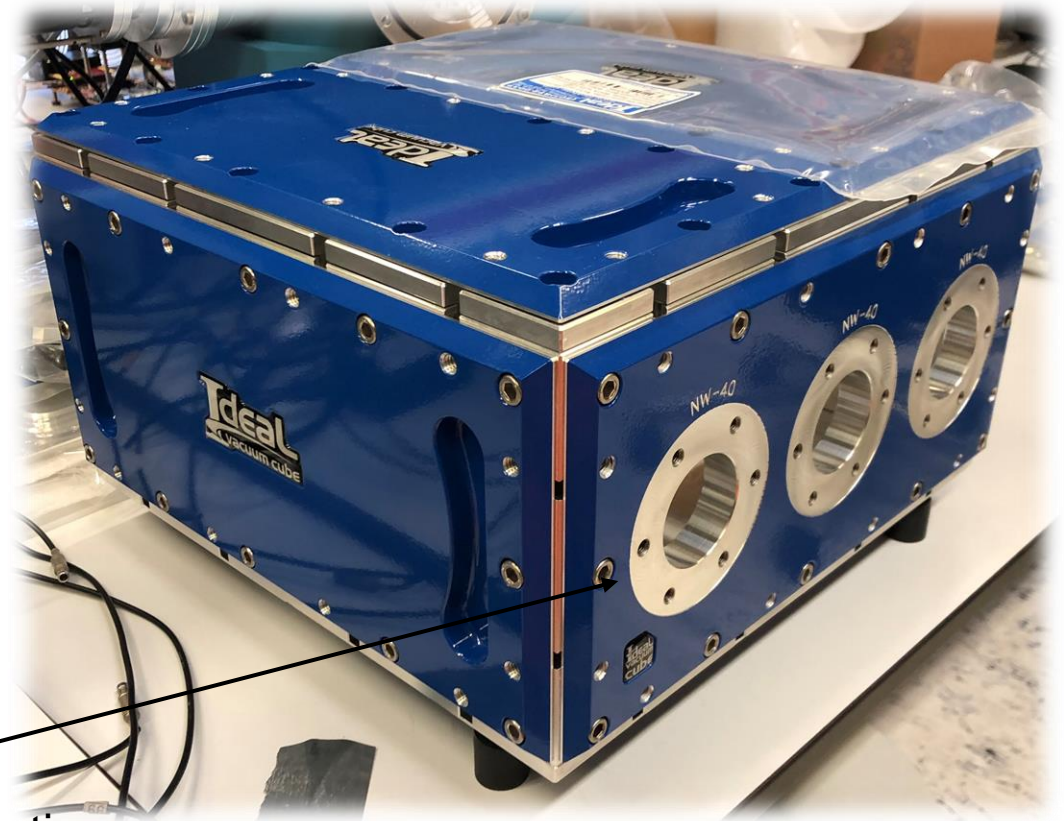
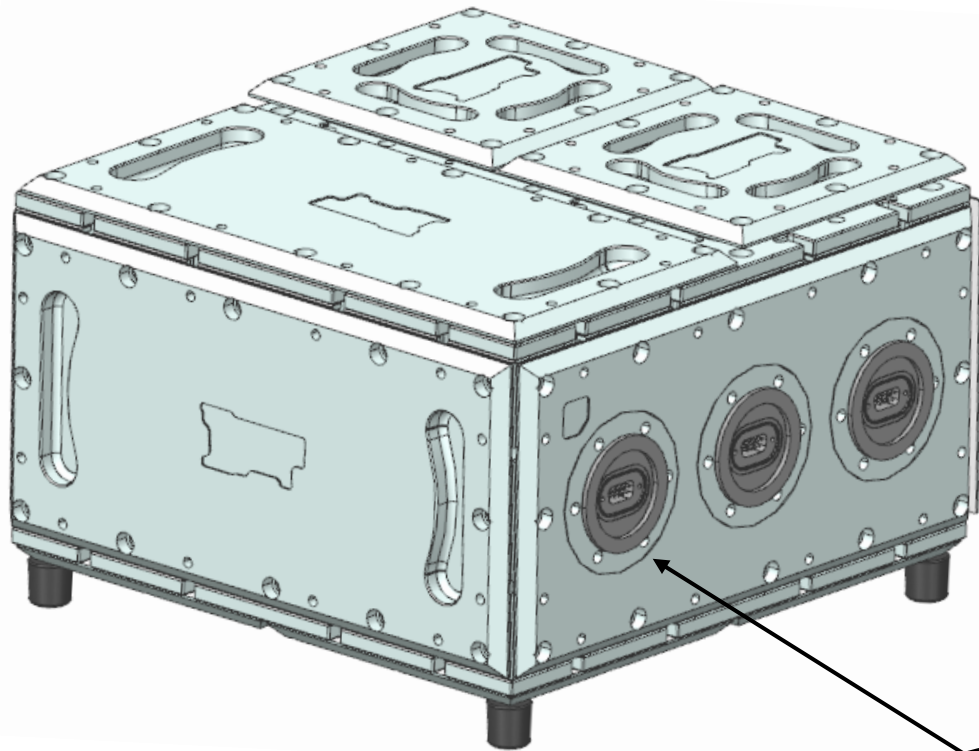
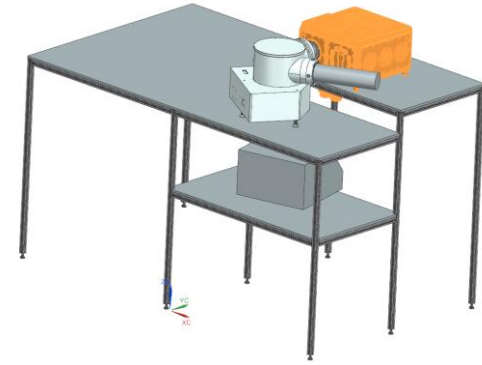

NW-40 9 pin Dsub connections

The Vacuum Chamber

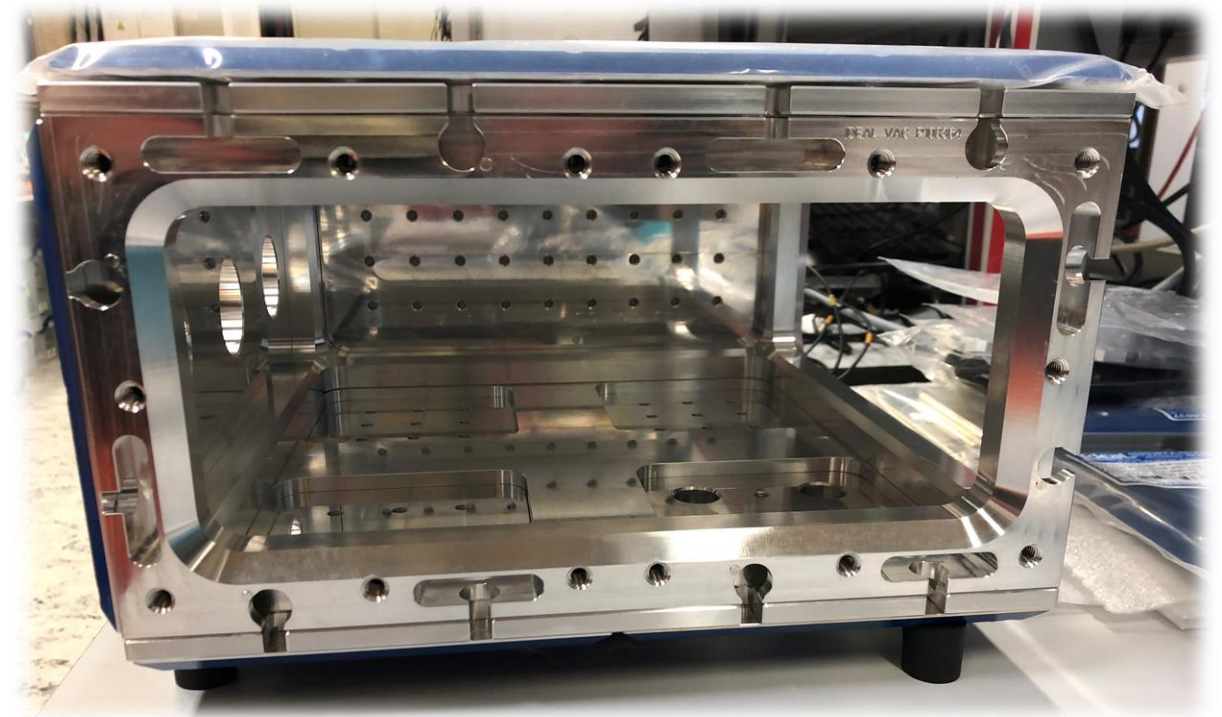
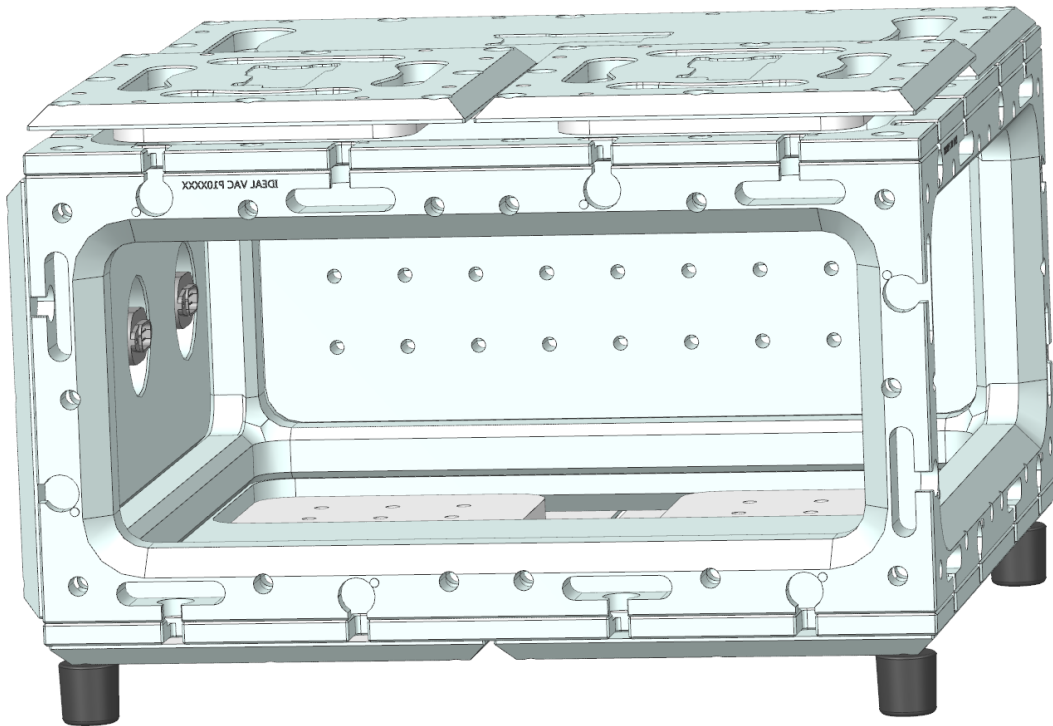
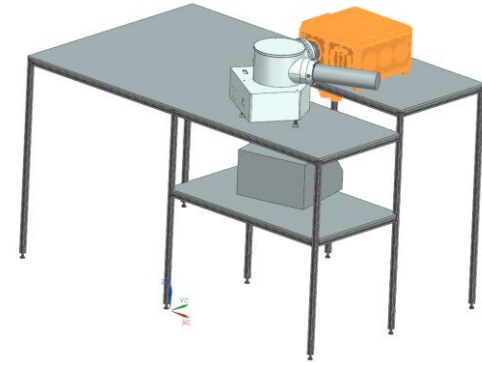

The Vacuum Chamber

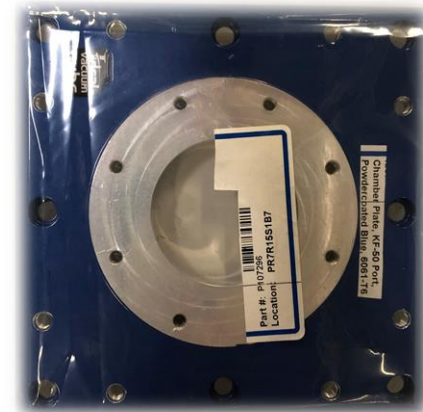
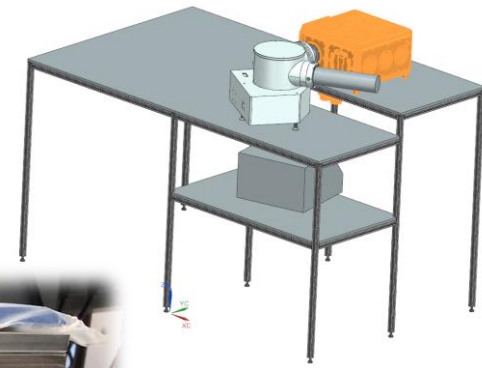
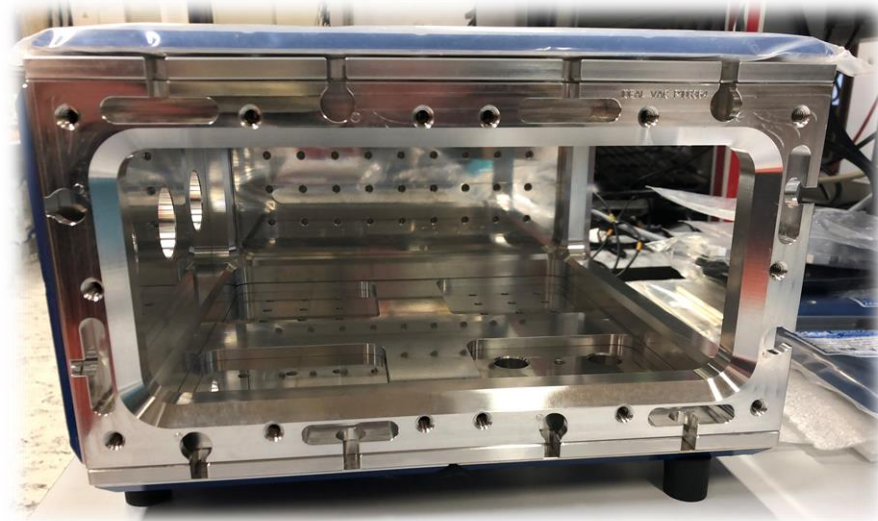
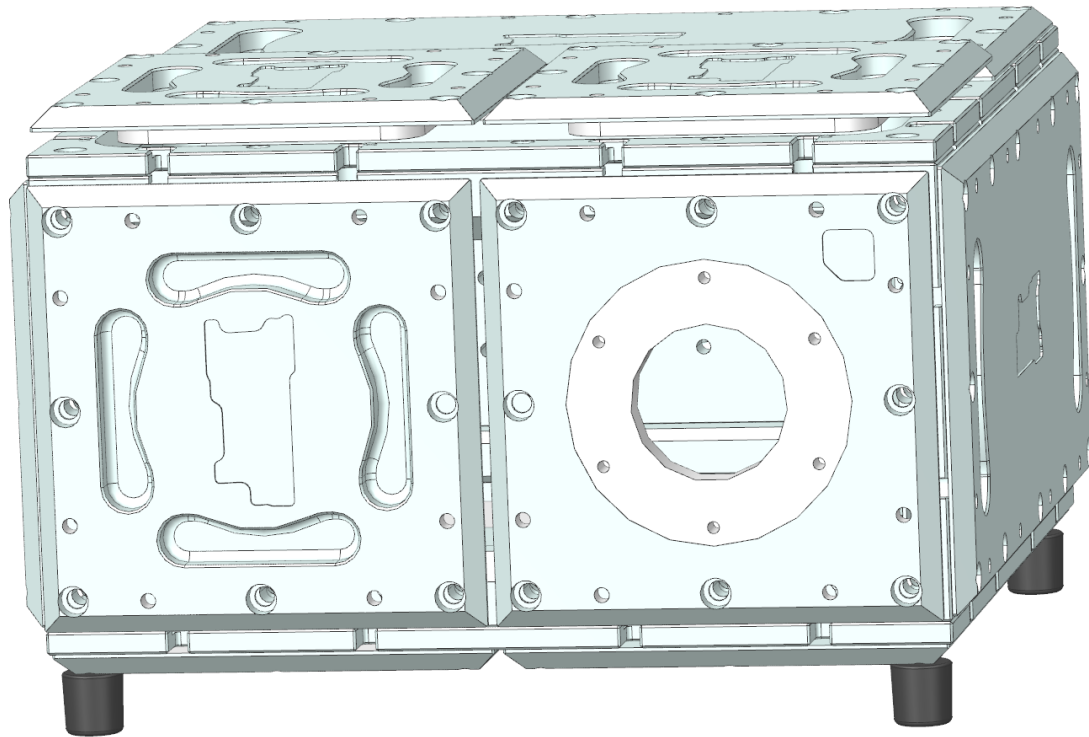

The Vacuum Chamber

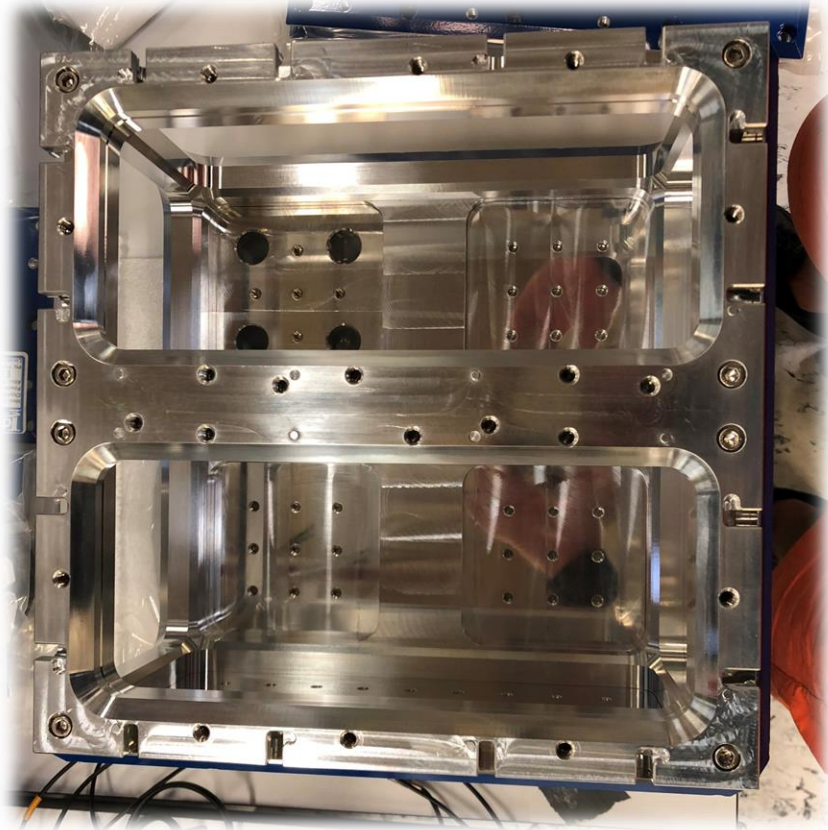
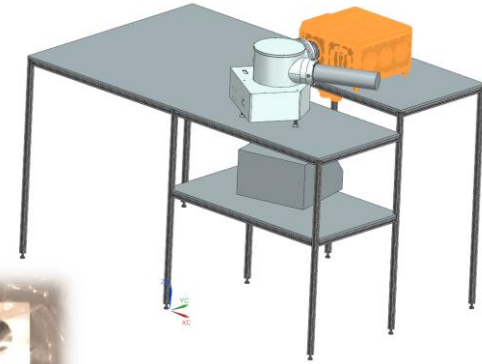

The Vacuum Chamber

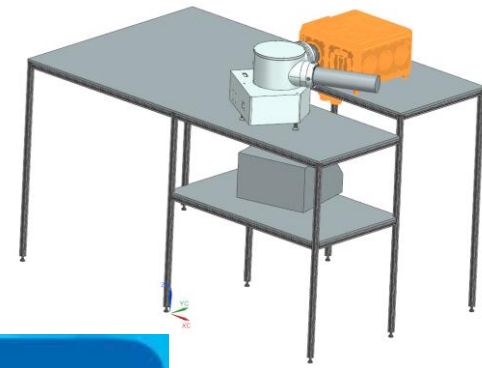

TAPER SEAL TECHNOLOGY

Ideal Vacuum Cubes are manufactured with our innovative sealing edge "Taper-Seal" design which forms a tapered groove seal (see green areas on the graphic). This helps prevent O-ring seals and sealing surfaces from contacting common work table tops. Our Taper-Seal prevents damage on the sealing areas for better vacuum performance.

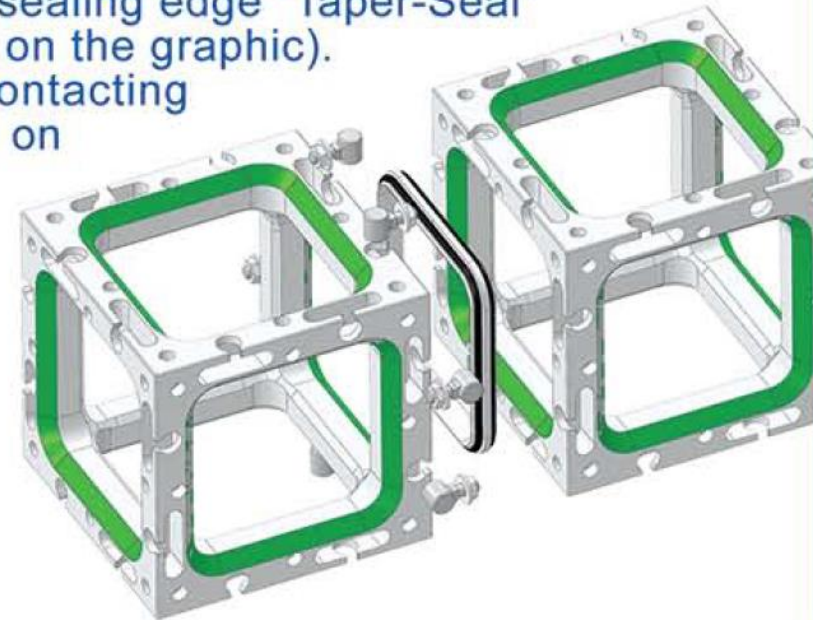
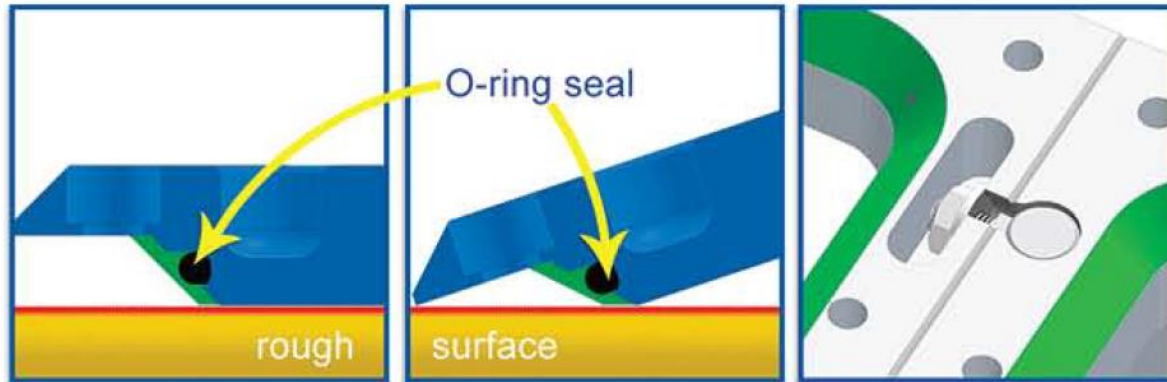

The Vacuum Chamber

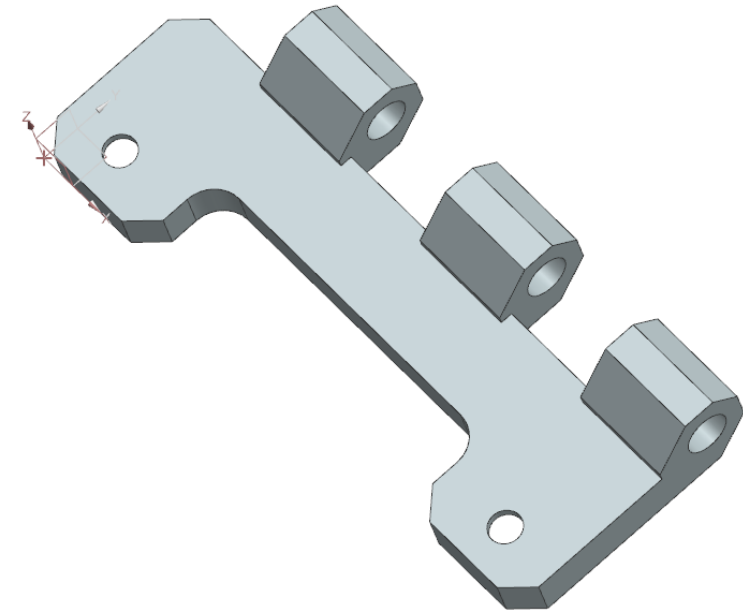
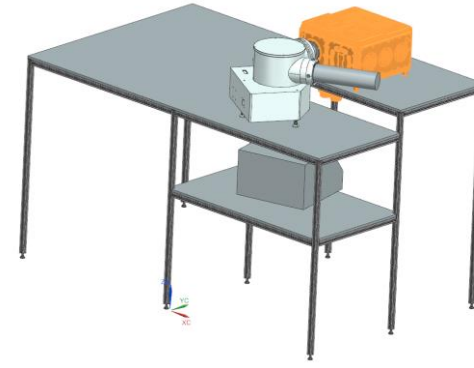
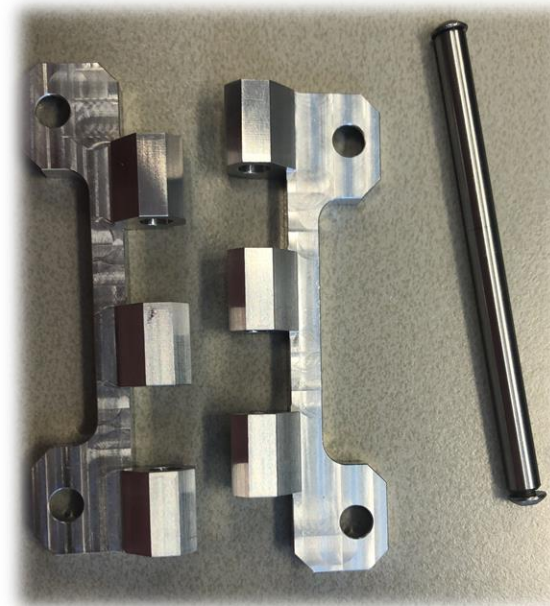
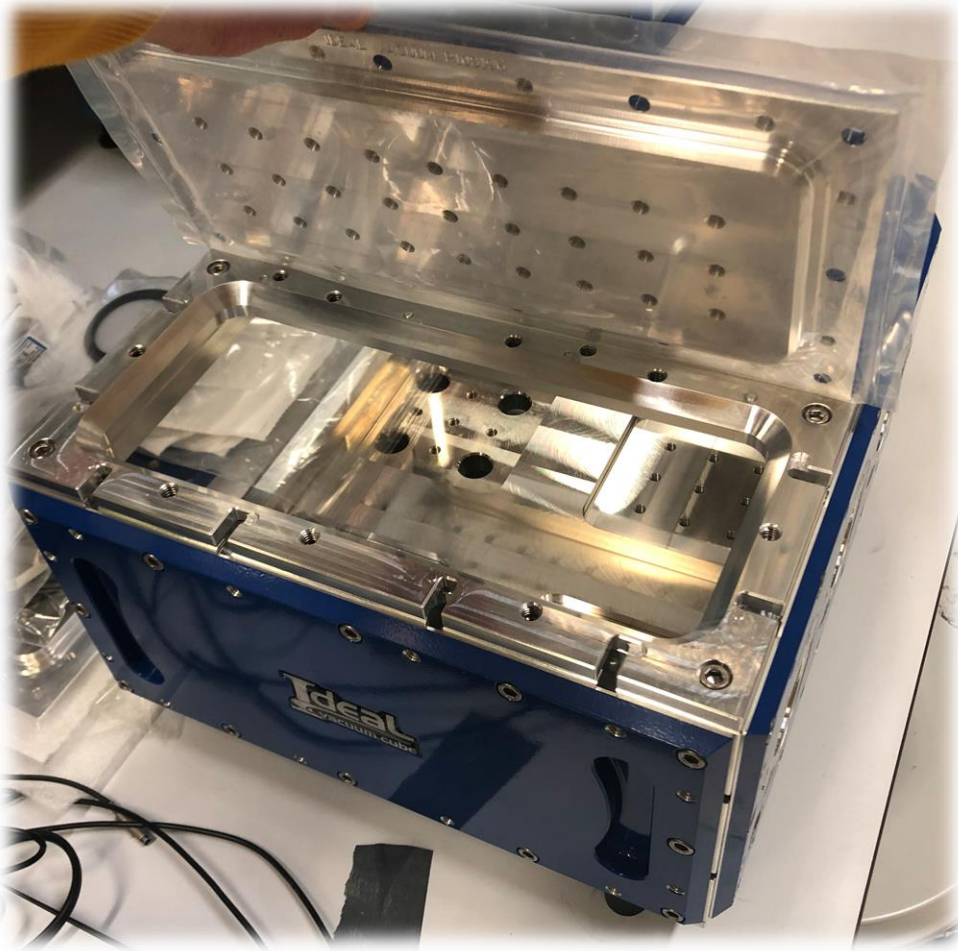

The Vacuum Chamber



Nitrogen container

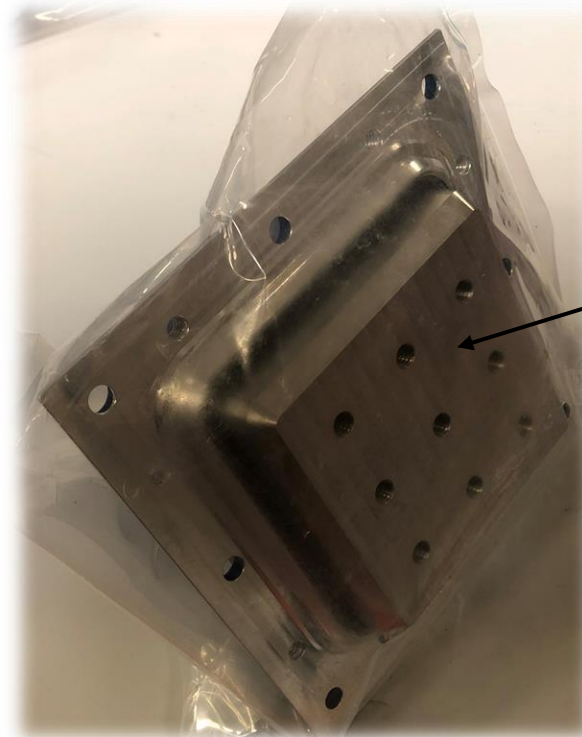
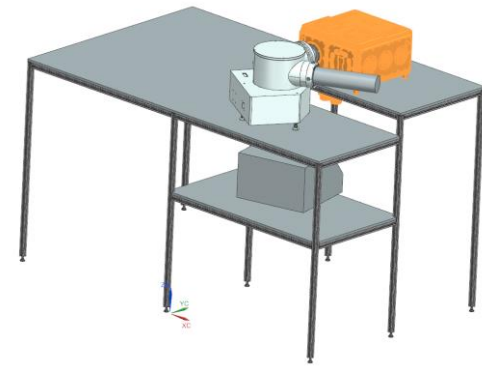

Cooling plate
(in the vacuum)

Table

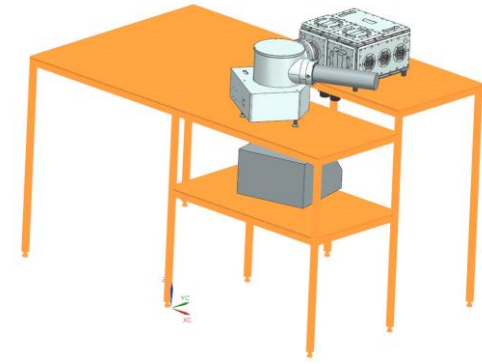
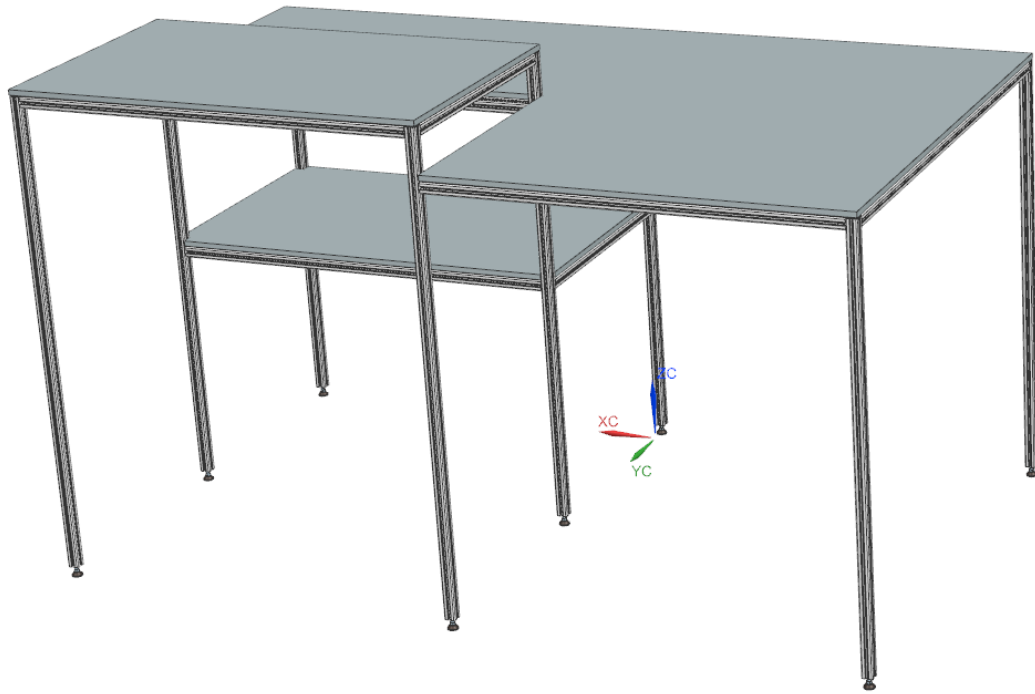

Table

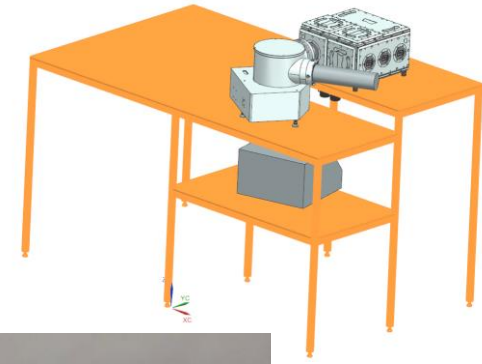
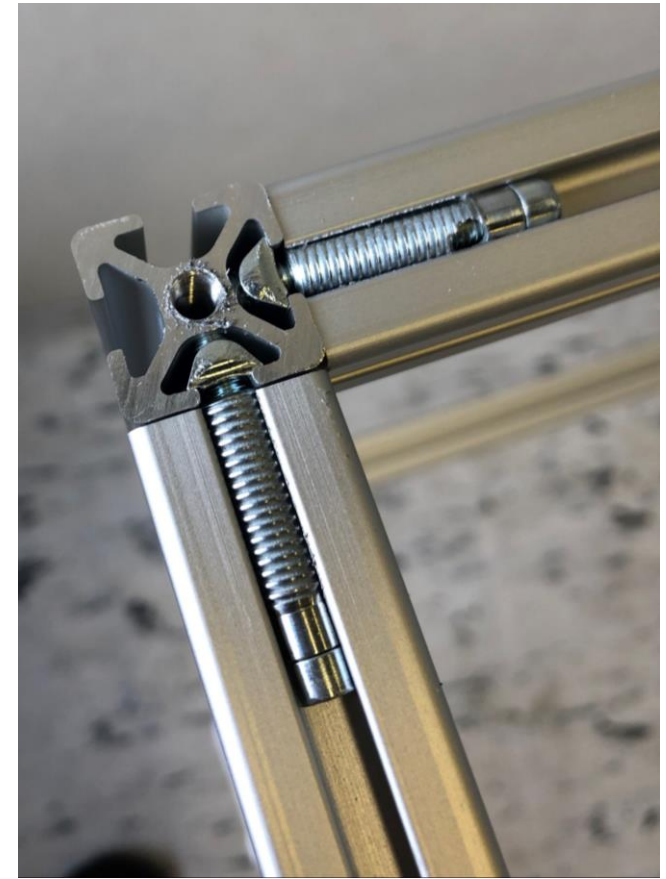

Table

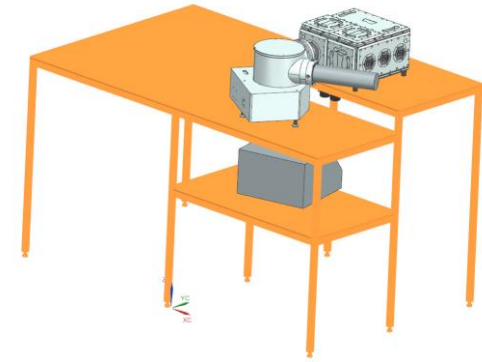

Table

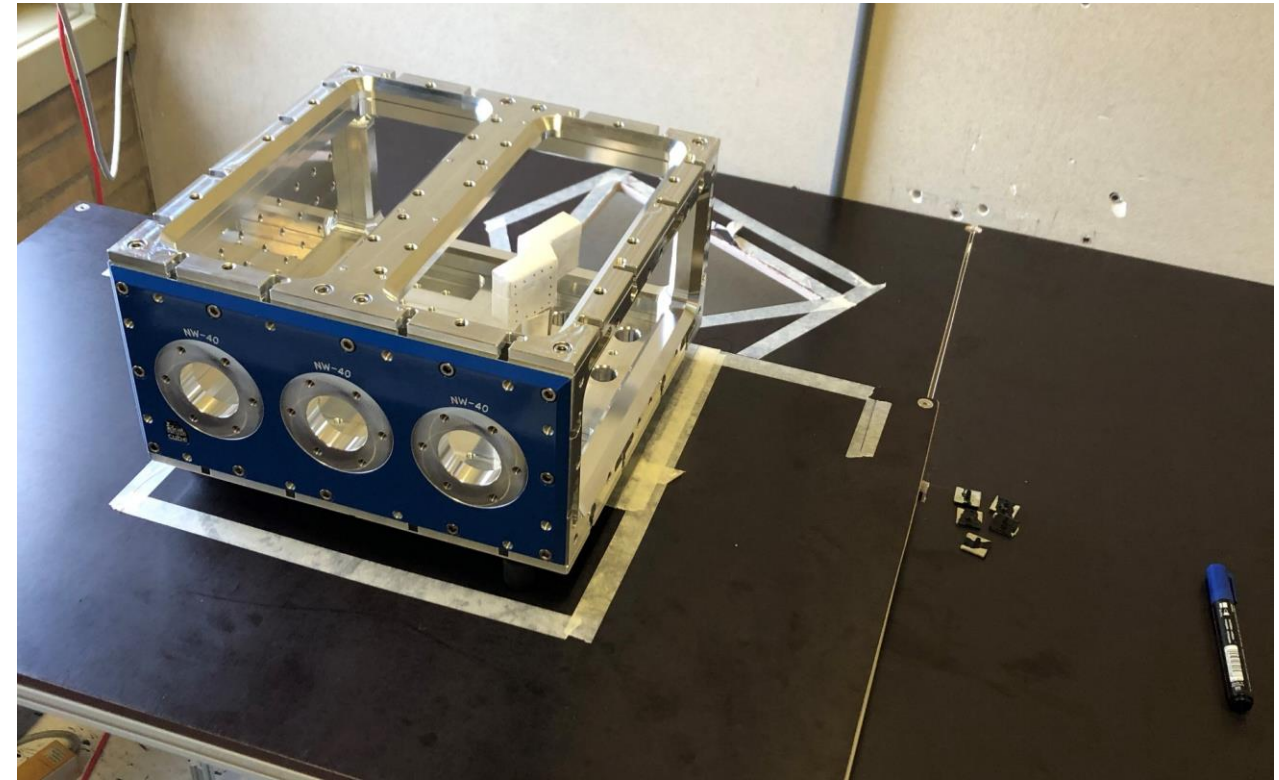
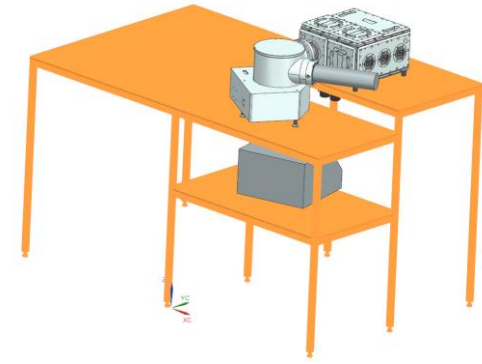
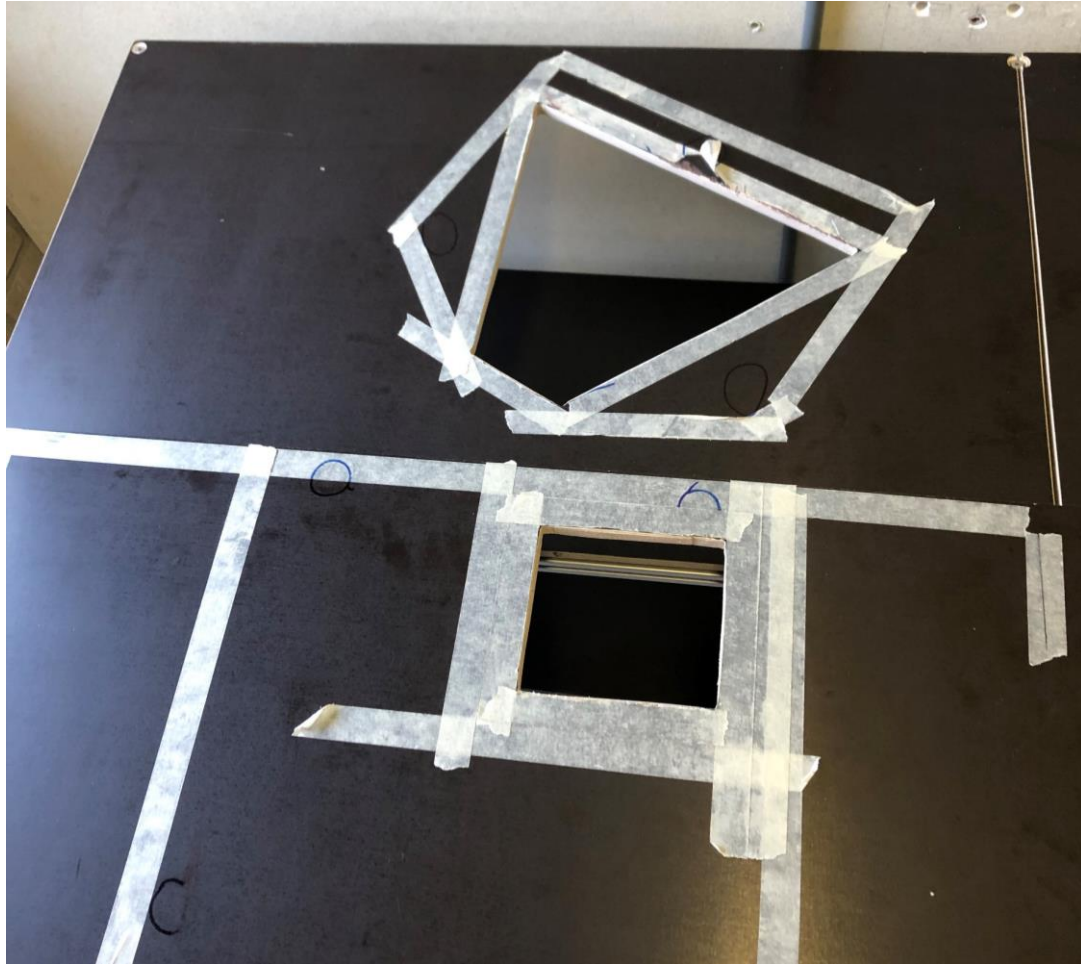

New Sample holder design

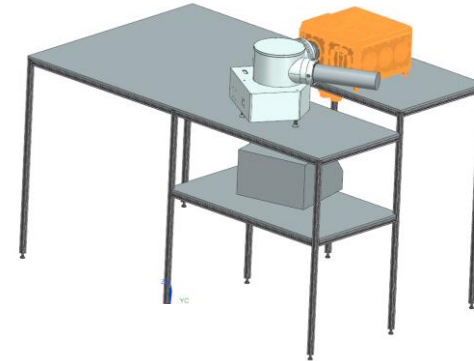
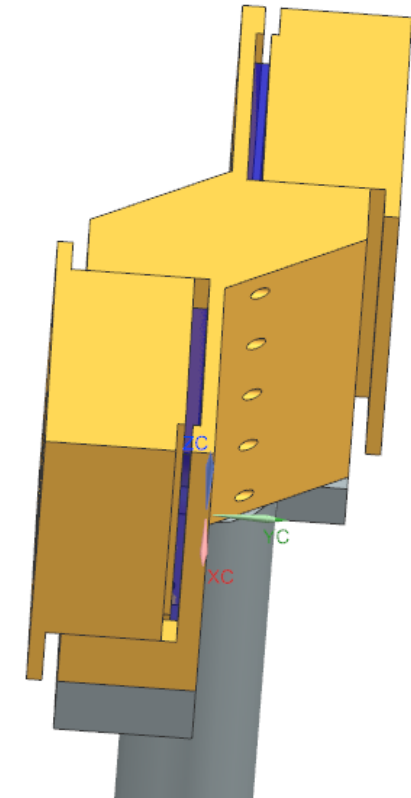
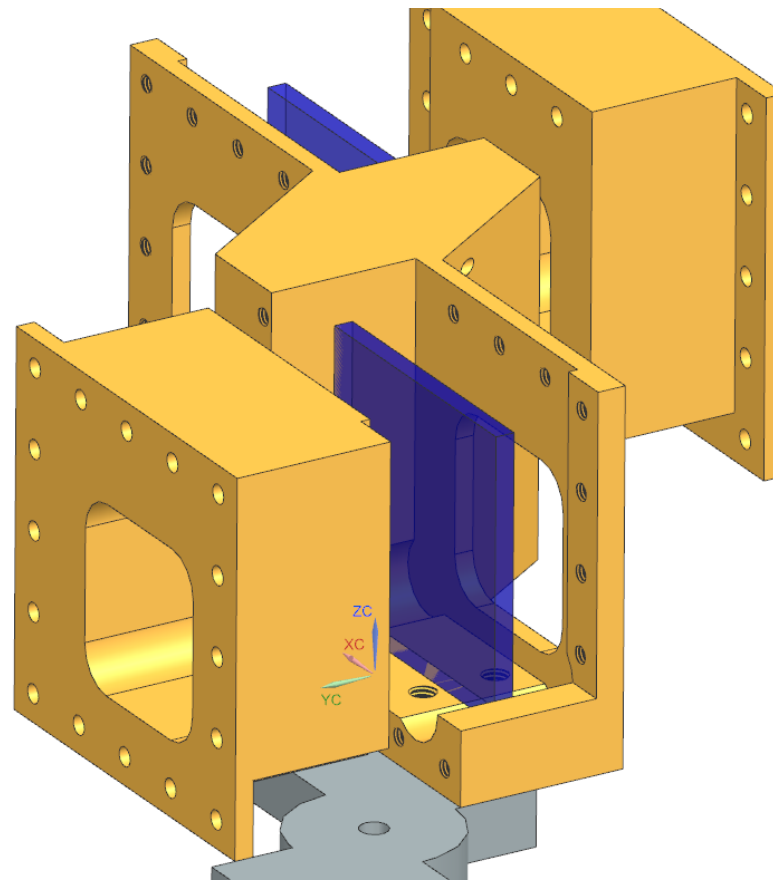
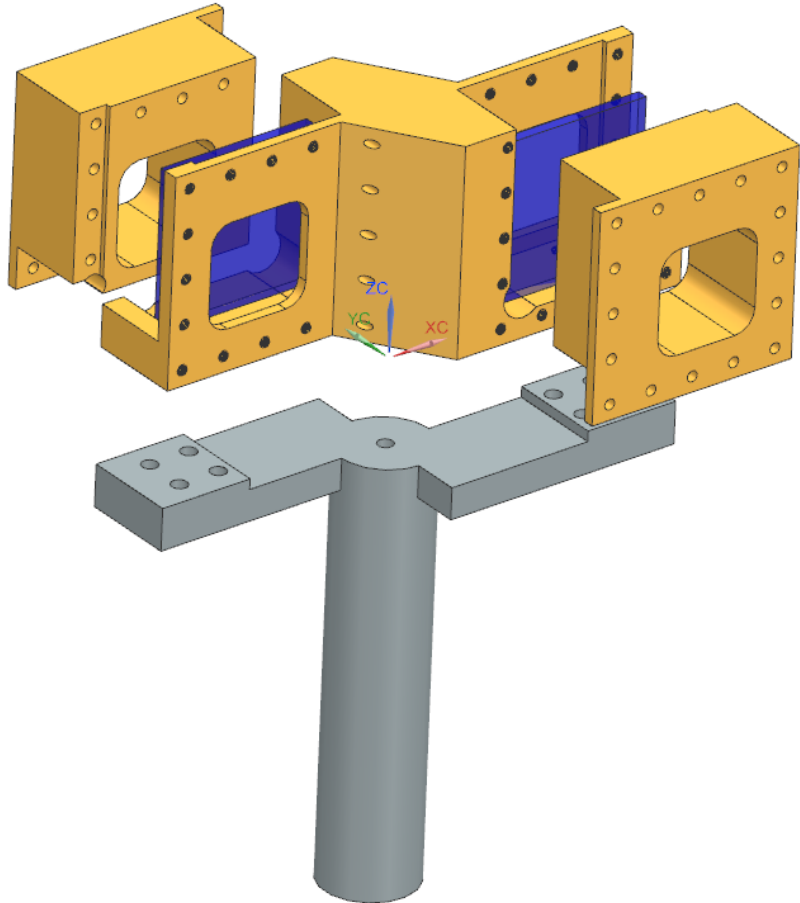

Testing accessibility

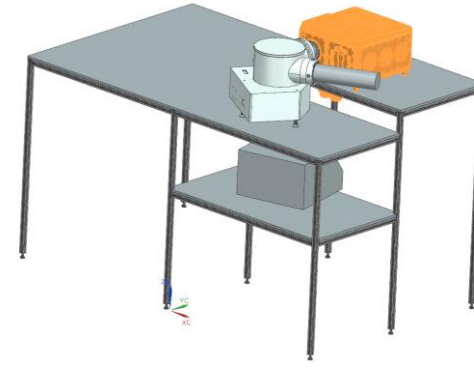
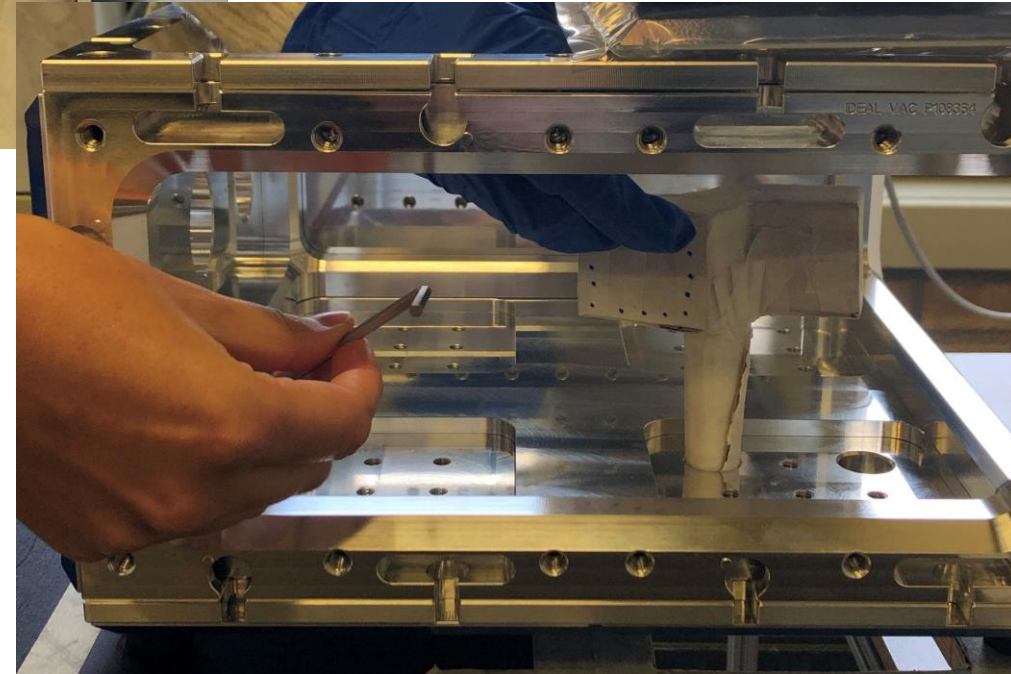
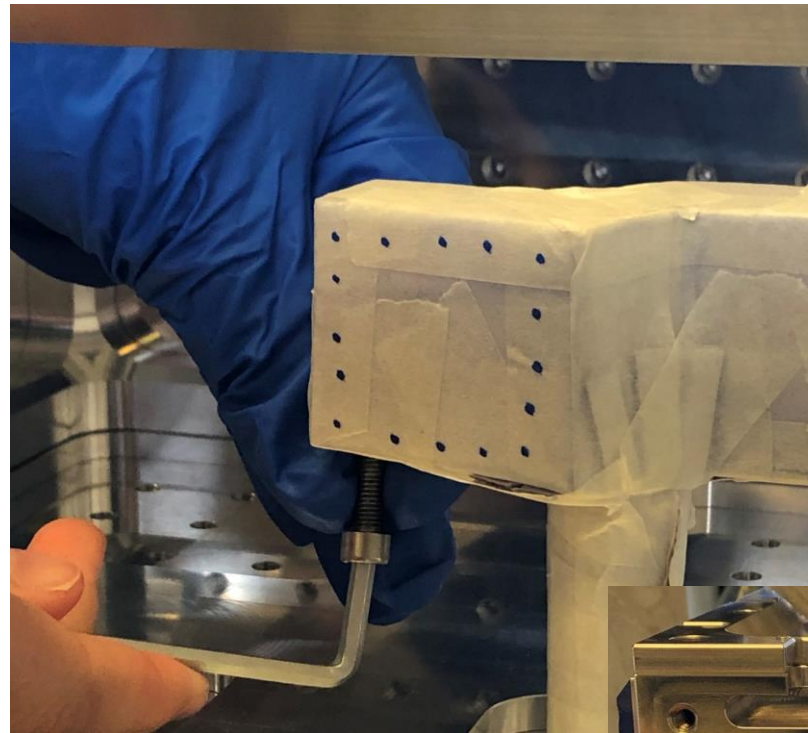

Data acquisition

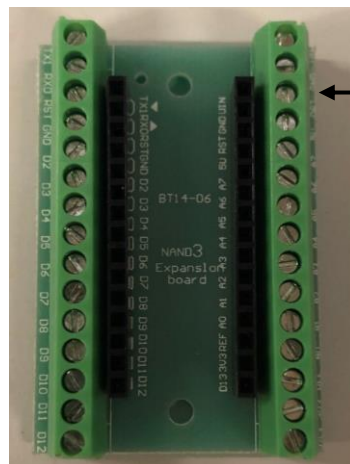
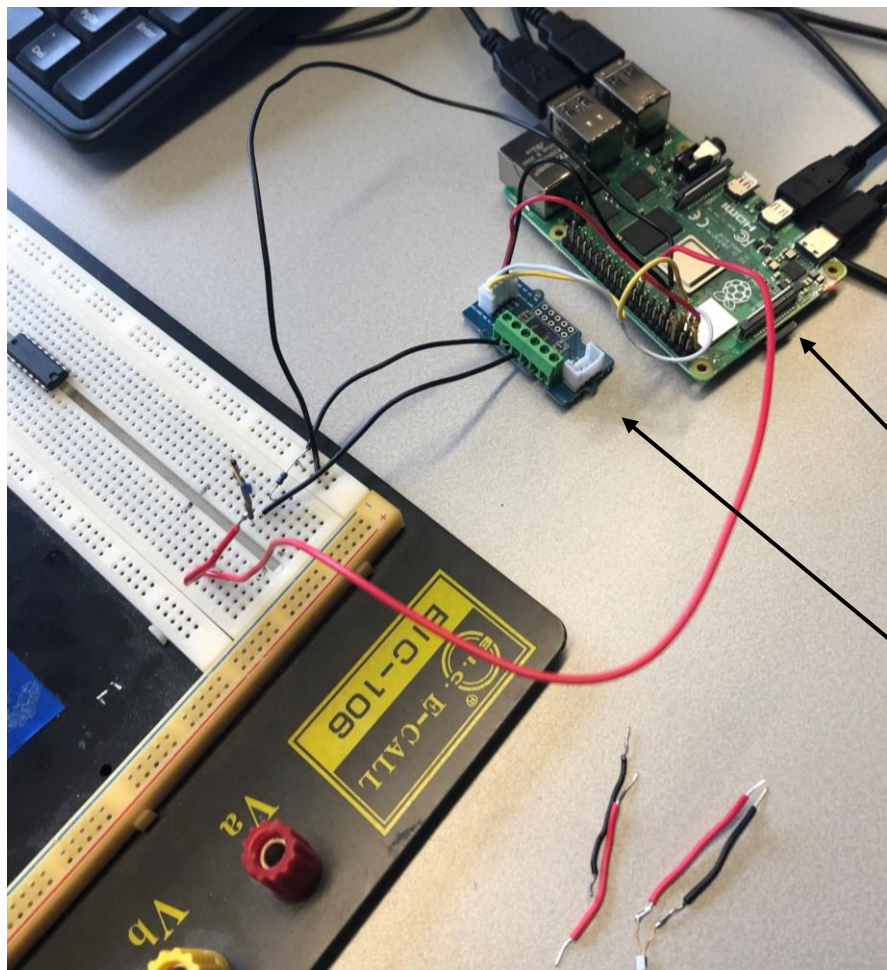
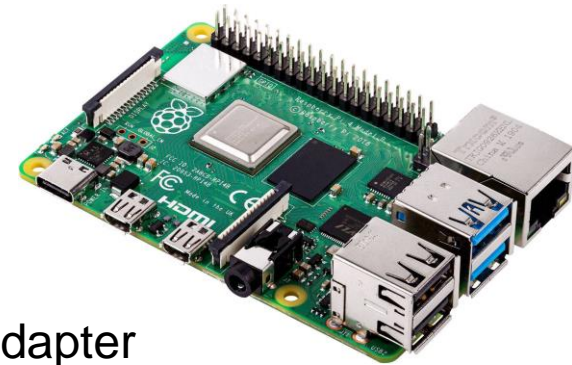

← Arduino connection adapter

Modified connection adapter

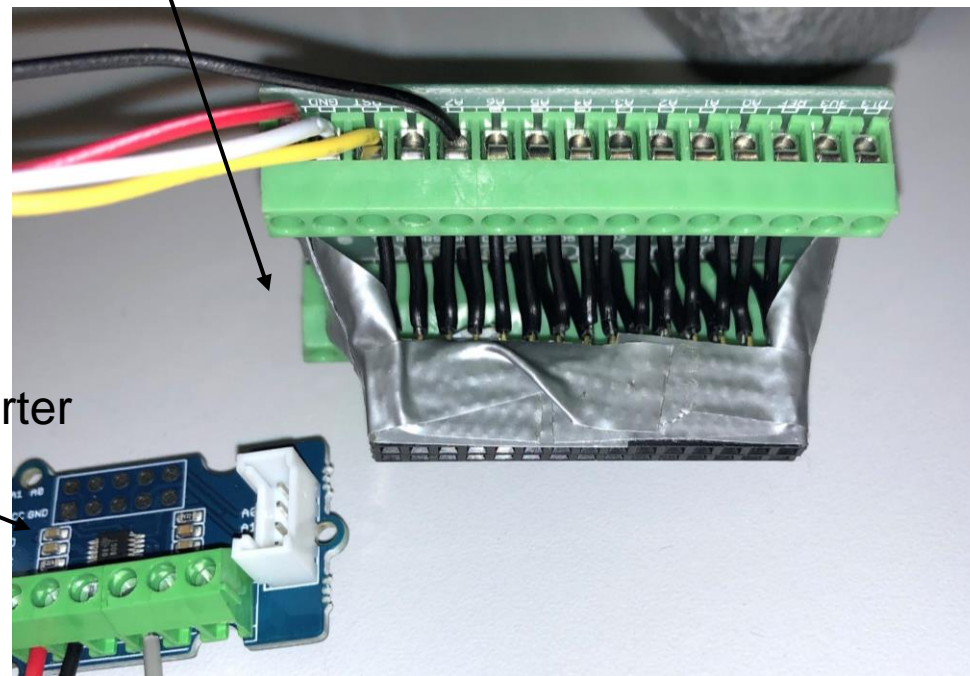

→ Raspberry Pi

→ Analog-Digital converter

Data acquisition

