

# Ideal vacuum cube

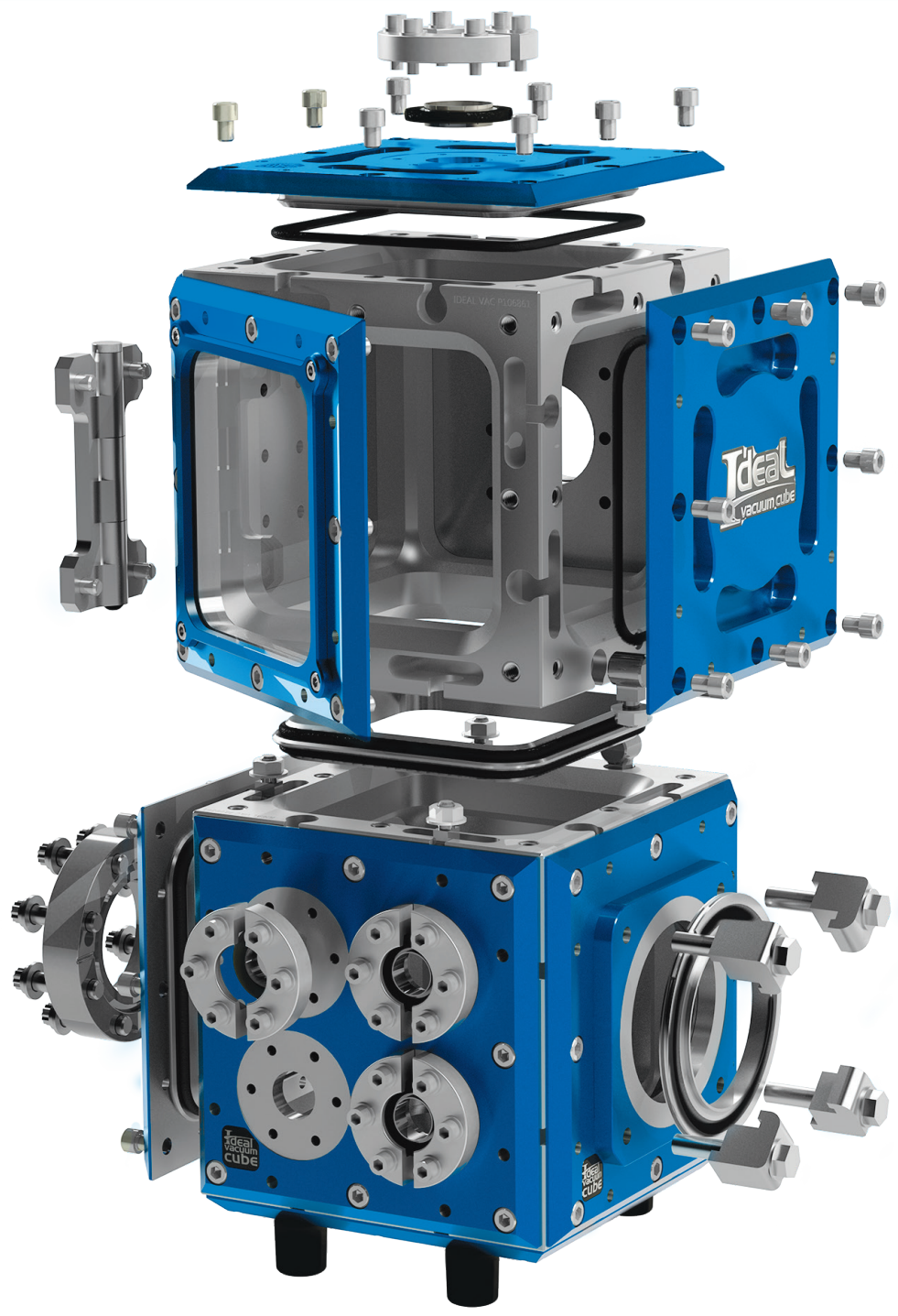
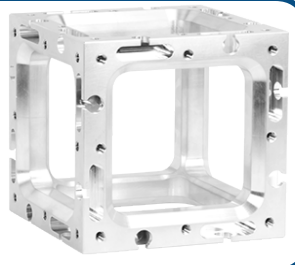

# Ideal vacuum cube

## User Manual

### Table of Contents

<b><u>6x6x6 Vacuum Cube Specification Sheet</u></b> .....	3
<b><u>Assembling a Vacuum Cube system</u></b> .....	3
<u>Vacuum Cube Frame</u> .....	3
<u>Plate Installation</u> .....	4
<u>Mounting for Cube Plate Accessories</u> .....	5
<u>Cube Coupling</u> .....	6
<b><u>Vacuum Port Connections</u></b> .....	6
<u>NW/KF Connections</u> .....	6
<u>CF Connections</u> .....	7
<u>ISO Connections</u> .....	7
<b><u>Window Plate Assembly</u></b> .....	8
<b><u>Accessories</u></b> .....	8
<b><u>Thermal Vacuum Cube Plates</u></b> .....	9
<u>Liquid Nitrogen Insert</u> .....	9
<u>Circulatory Thermal Insert</u> .....	10
<b><u>Vacuum Cube Operation</u></b> .....	11
<u>System Cleaning</u> .....	11
<u>Baking</u> .....	11
<u>Rough Vacuum</u> .....	12
<u>High Vacuum</u> .....	13
<b><u>Ordering List</u></b> .....	14
<u>Accessories</u> .....	14
<u>Plates Reference</u> .....	14
<u>Exploded View</u> .....	15

## 6x6x6 Vacuum Cube Specification Sheet

Dimensions	
6x6x6 Cube Volume	83.5 in <sup>3</sup> (1.37 Liters)
6x6x6 Cube Inside Dimensions	4.38" x 4.38" x 4.38" (111.4 mm x 111.4 mm x 111.4 mm)
6x6x6 Cube Inside Surface Area	110.3 in <sup>2</sup> (711 cm <sup>2</sup> )
Vacuum Cube Material	6061 Aluminum
6x6x6 Cube Mass ( <b>No Plates</b> )	3.74 lbs (1.7 kg)
Accessory Mounting Threads	1/4"-20
Pressures	
Cube Ultimate Vacuum Pressure	3x10 <sup>-8</sup> Torr
Maximum Cube Internal Positive Pressure	15 psig
Vacuum Cube Leak Rate	1x10 <sup>-8</sup> std cc/sec atm
Temperatures	
Maximum Operating Temp (Viton Seals)	150°C (300°F)
Minimum Operating Temp (Viton Seals)	-20°C (-4°F)
Optional Accessory Recirculator Fixture	150°C to -100°C (302°F to -148°F)

## Assembling a Vacuum Cube System

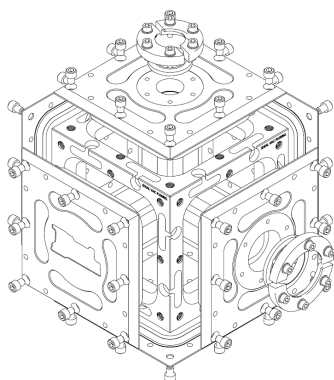

The Ideal Vacuum Cube is a modular high-vacuum chamber system, conceived to enable creativity and design flexibility in vacuum chamber system construction. Cubes can be stacked together into various shapes and configurations, with interchangeable plates offering a variety of features for connections, windows, and feedthroughs.

Configuring and building a Vacuum Cube chamber is a simple process. Once the desired plates have been selected, they can be quickly assembled onto the Cube Frame. Single or multiple plates can be easily swapped when reconfiguration is needed.

### Vacuum Cube Frame

The core of a Vacuum Cube chamber system is the Cube Frame. Machined from 6061 aluminum alloy and reinforced with stainless steel thread inserts, a Cube Frame accepts a single Vacuum Cube Plate on each side (6 total).

A 6x6x6 Vacuum Cube Frame is machined as an exact 6.000” cube. See Figure (1) for additional dimensions. The exterior size of a fully assembled Cube system will vary based on the types of plates equipped.

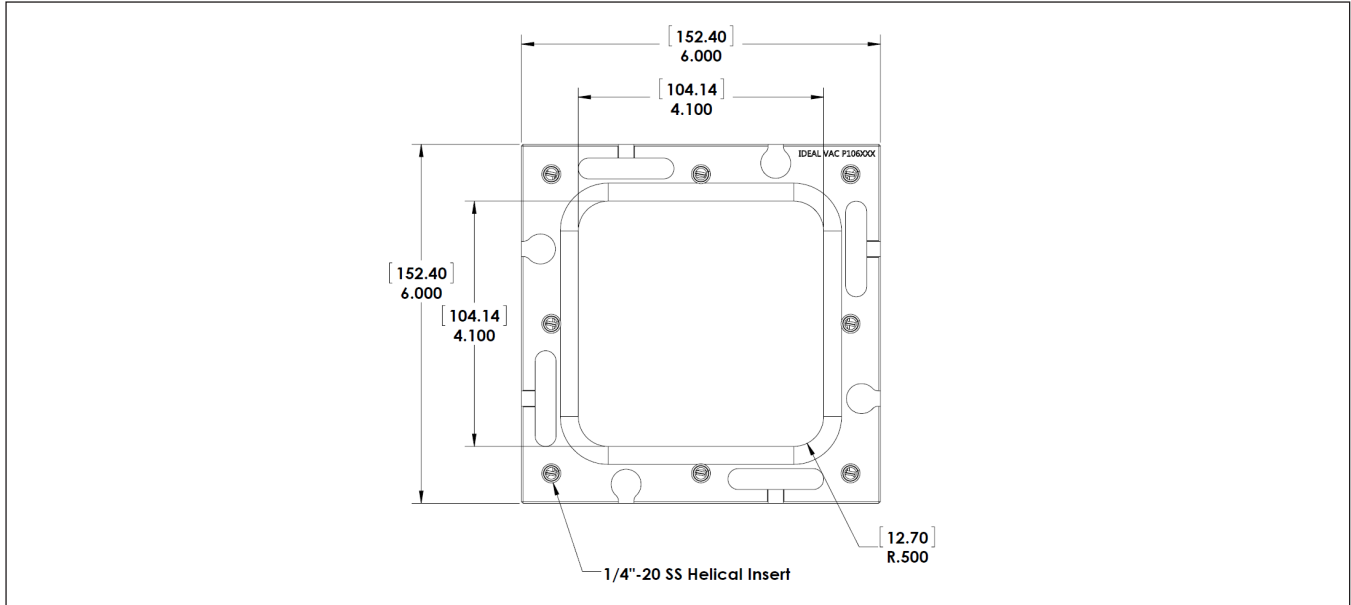

## Plate Installation

On the underside of each Cube Plate is a tapered O-ring groove. Before installing a Plate onto the Cube Frame, carefully clean the O-ring groove and install a clean O-ring around the groove. For the best vacuum performance, be sure the installed O-ring has minimal twist. In the same way, ensure the tapered sealing surface of the Cube is also clean before positioning the plate.

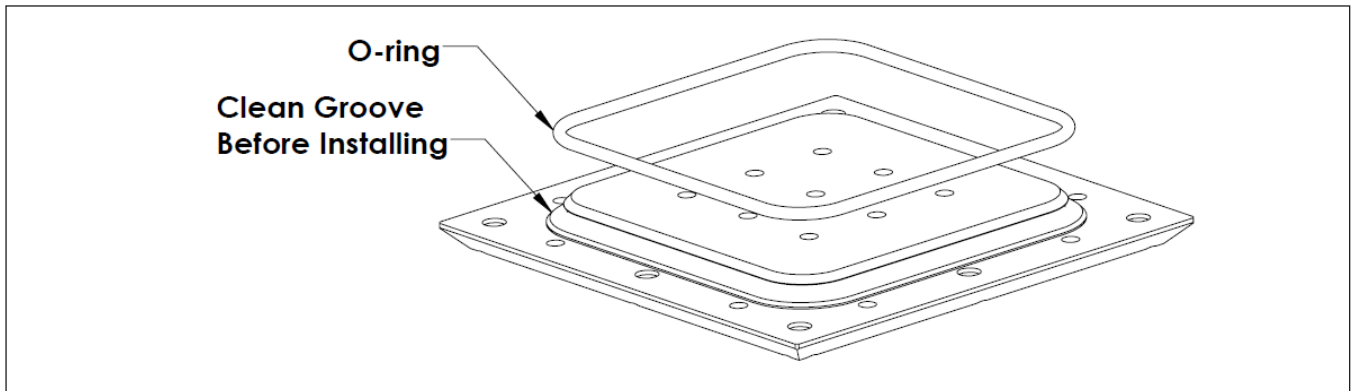

O-rings can be re-used many times, but should be discarded if the material has been nicked, torn, or otherwise damaged. An O-ring should also be replaced if the cross-section becomes permanently deformed and is no longer round.

Plates are fastened to the Cube with 1/4"-20 x 5/16" long socket head cap screws (3/16" head size). When installing each plate, begin by inserting and gradually tightening 2 opposite mounting screws until the Plate sits flush against the Cube. Then, install all remaining fasteners and torque in a "star" star pattern to 75 in/lbs.

Vacuum Cube components are machined to very precise tolerances so that Plates will sit very flat against the Cube and create a consistent seal over varying fastener tensions; over-tightening will not improve the vacuum performance.

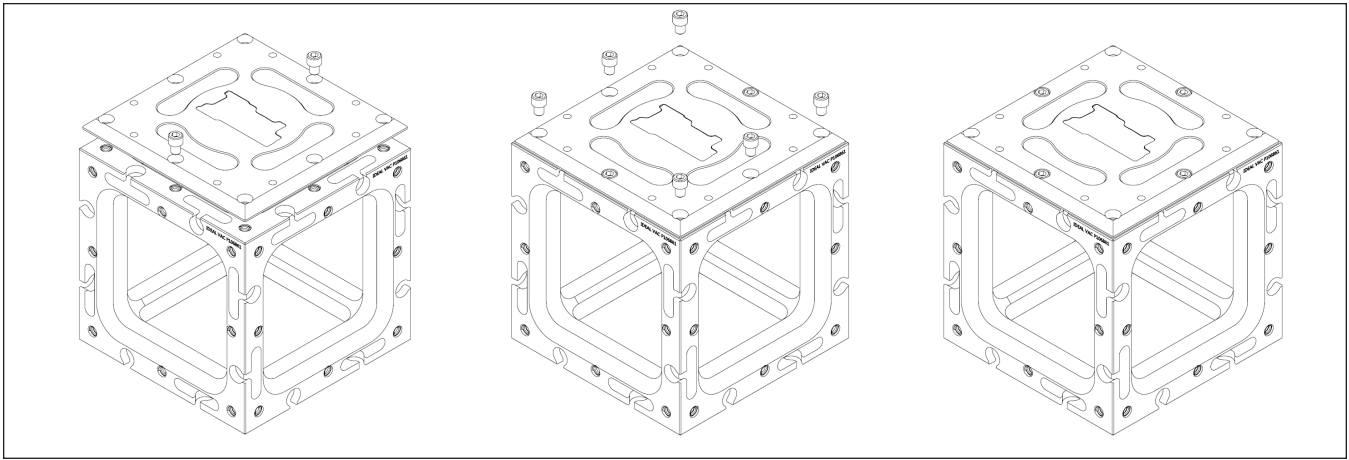

In a 6x6 Vacuum Cube system, each Plate accepts up to 8 mounting bolts. If it is necessary to ensure the best vacuum performance, install all bolts into the plate. For quick installation, a minimum of 4 mounting bolts may be used, skipping either the center or corner fasteners.

	<p><b>WARNING</b></p>		<p>A Vacuum Cube system can be pressurized to a maximum of 15 psig positive pressure. When pressurizing a Vacuum Cube, it is important to install ALL 8 plate mounting bolts for each installed plate. Serious injury or death may occur if a Vacuum Cube is pressurized improperly or beyond its rated limit!</p>
<p>Warnings are given where failure to observe the instruction could result in injury or death.</p>			

### Mounting for Cube Plate Accessories

Vacuum Cube Plates are configured with multiple 1/4"-20 threaded mounting holes for adding both internal and external accessories to a Vacuum Cube system.

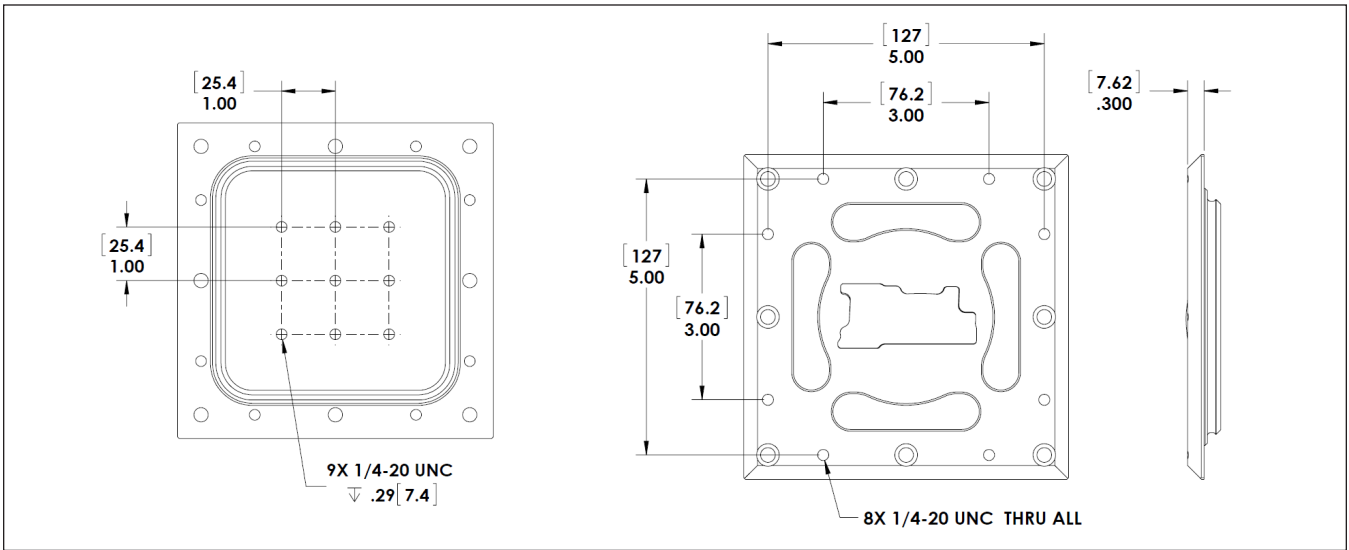

For the best vacuum performance, it is recommended to use vented 1/4"-20 fasteners when attaching internal accessories to the Vacuum Cube. This helps prevent virtual leaks in the form of trapped air volumes under internal mounting screws.

When mounting external accessories to the Vacuum Cube, be sure to select 1/4"-20 hardware which requires .300" or less thread engagement.

## Cube Coupling

If needed, multiple Vacuum Cubes can be coupled together to create larger chamber volumes in varying shapes and sizes. Coupling kits can be used to attach 2 or more Cubes together.

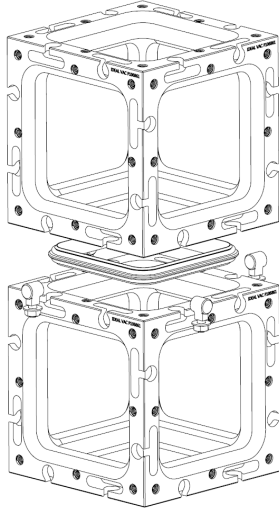

A cube coupling kit for a 6x6x6 Cube contains a Coupling Seal and 4 Coupling Connectors. The Coupling Seal is placed between the two Cube Frames, and at alternating fastening points between the Cubes, a Coupling Connector can be installed.

To ensure the Cube Frames are aligned with each other, it is helpful to place the cubes together on a flat surface as the coupling connectors are tightened. Torque the coupling connectors in a “star” pattern to pull the Cube together. Once the faces of each Cube Frame have made full contact, tighten the coupling connectors with a  $\frac{7}{16}$ ” wrench until they are snug. As with Plate installation, do not over-torque cube coupling hardware; this will not improve the vacuum seal.

Coupling Connector

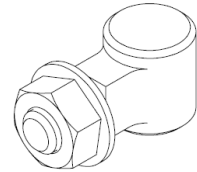

## Vacuum Port Connections

6x6 Cube Plates are available with a number of standard vacuum port types and sizes:

### NW/KF Connections

Standard NW/KF style centering ring assemblies can be used to make NW style connections to the Vacuum Cube. These connections can be secured with the use of 2-piece bulkhead clamps, 10-32 x  $\frac{1}{4}$ ”  $\frac{5}{8}$ ” socket head cap screw 32 in./lbs. max torque  $\frac{3}{8}$ ” max thread depth.

- NW-16
- NW-25
- NW-40
- NW-50

NW/KF Centering Ring

Bulkhead NW Clamp

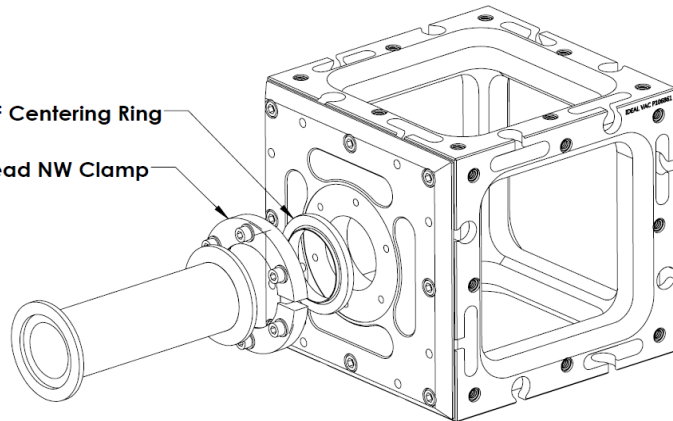

## CF Connections (Conflat®)

CF flanges can be attached to the Vacuum Cube with Viton CF style gaskets.

- CF 1.33, 8-32 x 0.50" Bolts
- CF 2.75, 1/4"-28 x 1.00" Bolts
- CF 3.375, 5/16"-24 x 1.00" Bolts
- CF 4.5, 5/16"-24 x 1.00" Bolts

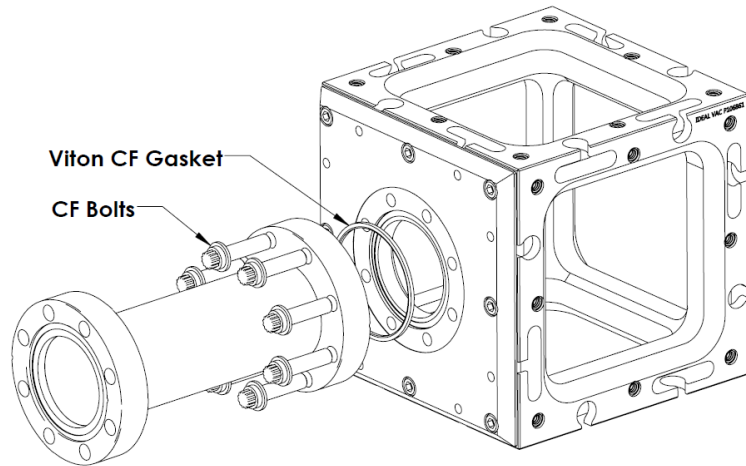

### WARNING

Warnings are given where failure to observe the instruction could result in product damage.



Vacuum Cube Plates with CF style ports are not compatible with copper gaskets! Use only Viton gaskets to avoid damaging the plate sealing surface.

## ISO Connections

- ISO-63, 5/16"-18 Single Claw Clamps
- ISO-80, 5/16"-18 Single Claw Clamps

ISO Centering Ring  
Single Claw Clamp

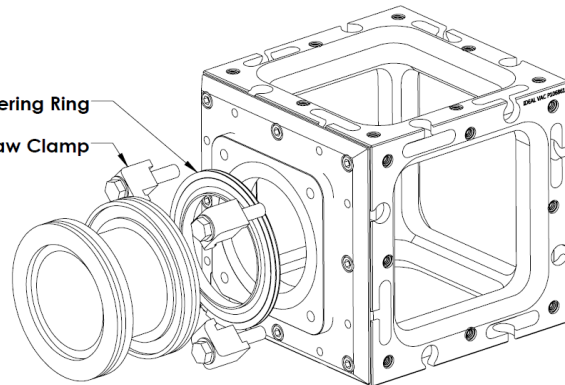

In systems where a standard plate design cannot be used, Ideal Vacuum can custom design and manufacture plates for unique applications. Machine-able blank plates are also available to designers who wish to create their own custom plates.

## Window Plate Assembly

Before a Window Plate can be added to a Cube system, it must first be pre-assembled. Before assembly, clean the O-Ring groove and inspect the Window O-ring Seal for damage. Likewise, before inserting the Glass Pane, inspect the Pane for chips or cracks. If the Glass Pane is damaged, replace it immediately.

Installation of Window Assembly components is shown in the figure below. The Glass Pane is held in place by a Window Trim Ring. The Window Trim Ring is held in place by four 8-32 x 1/4" socket head cap screws. Use a 1/8" wrench to torque to 22 in/lbs (max). Installation of a complete Window Plate assembly onto a Cube system is the same as other plate styles.

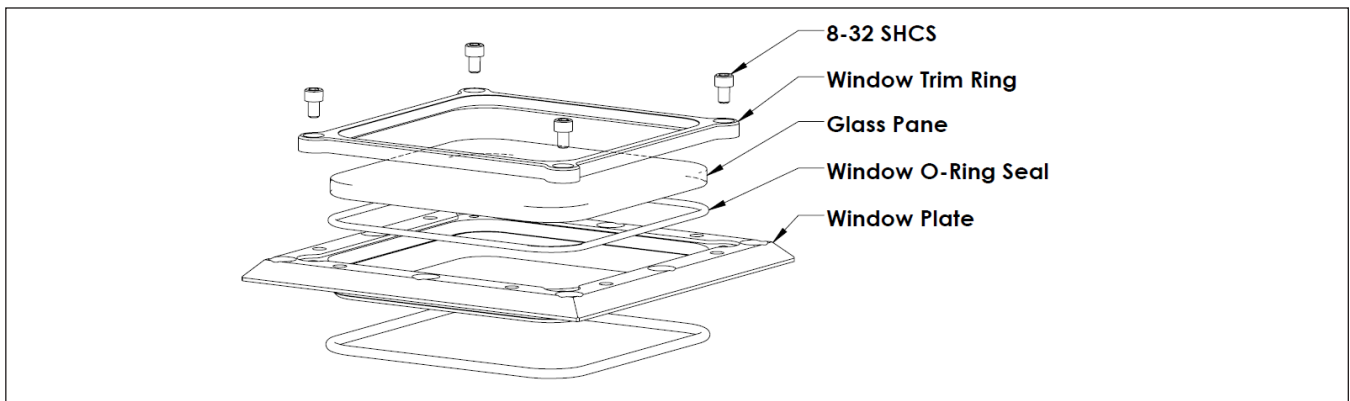

### WARNING

Warnings are given where failure to observe the instruction could result in injury or death.



Exercise care when working around windows and viewports. Safety Glasses should be worn at all times when operating a vacuum chamber. Windows can fracture and implode if struck by a hard object, causing personal injury or damage to the vacuum system.

## Accessories

Cube Plates have internal and external 1/4"-20 mounting threads for compatibility with standard optical components mounting hardware.

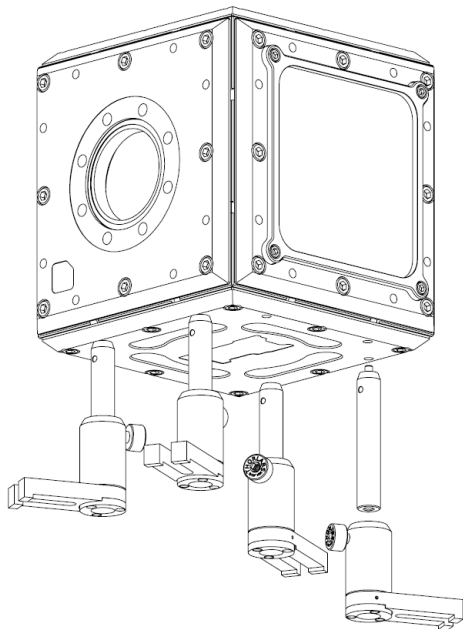

Rubber Vacuum Cube Foot Kit can be used for benchtop operation.

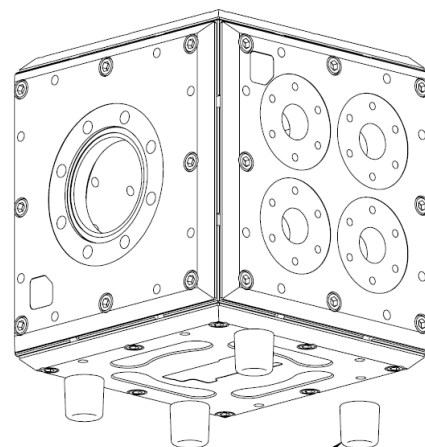

Rubber Mounting Foot

1/4"-20 Mounting Screw



The Vacuum Cube Hinge Kit is compatible with all Vacuum Cube Plates and can be used to convert any Plate into a door.

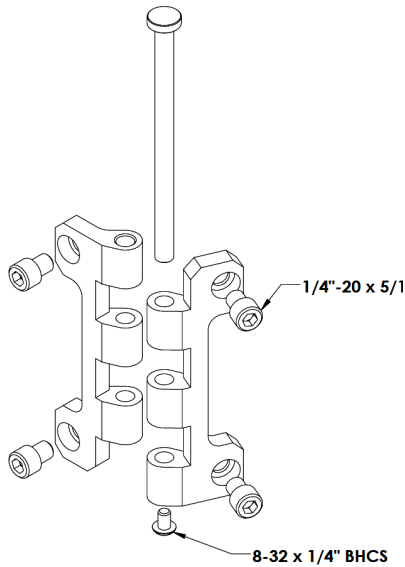

The Quick Knob Kit allows tool-less installation and removal of any Cube Plate. Four Quick Knobs are recommended for installing a single plate or two Quick Knobs can be paired with a Hinge Kit to create a quick access door.

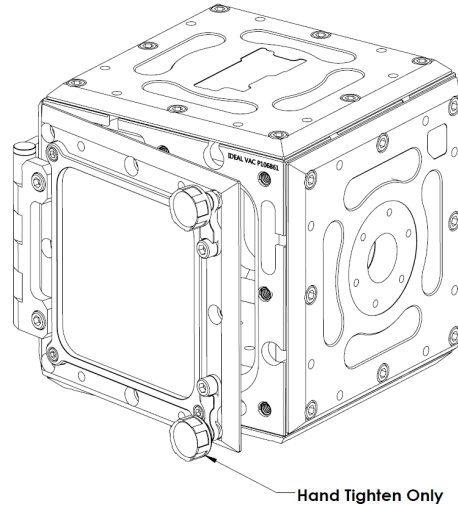

## Thermal Vacuum Cube Plates

6x6 Thermal Vacuum Plates are available for both recirculating and reservoir-based heating/cooling applications in Vacuum Cube chambers. Thermal Vacuum Plates feature a breadboard pattern tapped 1/4"-20 on 1" center for mounting standard test hardware components. (See "Mounting for Cube Plate Accessories")

### Liquid Nitrogen Insert

The Liquid Nitrogen insert can be used to achieve cryogenic conditions as low as -196°C. The 6x6 Plate insert has a reservoir volume of .14 Liters. Cooling the insert from room temperature requires approximately 1 Liter Of Liquid Nitrogen.

When operated on an evacuated Cube with no heat load, the reservoir life of the insert is approximately 240 mins.

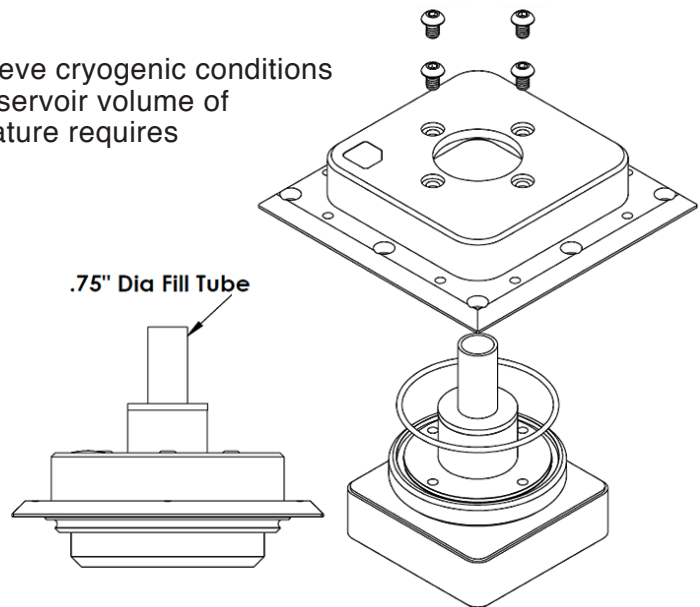
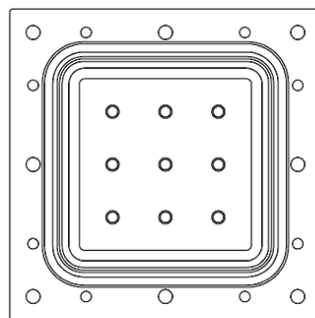

#### WARNING

Warnings are given where failure to observe the instruction could result in injury or death.



Liquid Nitrogen insert should be oriented vertically to avoid spills. Observe safe handling practices when working with liquid nitrogen and always use eye and hand protection.

## Circulatory Thermal Vacuum Insert

For precise temperature control, the Circulatory Thermal Vacuum Insert can be utilized to cool or heat a specimen.  $\frac{1}{4}$ " Stainless Steel circulation lines can be connected with compression style fittings. Flow direction through the insert is reversible.

With standard hardware and seals, the recommended temperature operating range of the circulatory insert is  $-200^{\circ}\text{C}$  to  $150^{\circ}\text{C}$ . If a greater temperature range is needed, contact Ideal Vacuum Products for information on upgraded seal and plate components.

When needed, the Circulatory Insert Plate can be disassembled for cleaning and inspection. When the cooling shroud is disassembled, inspect the internal O-ring and replace if damaged. Maximum installation torque of the four  $\frac{1}{4}$ "-20 x  $\frac{3}{8}$ " button head cap screws is 75 in/lbs. using a  $\frac{5}{32}$ " wrench

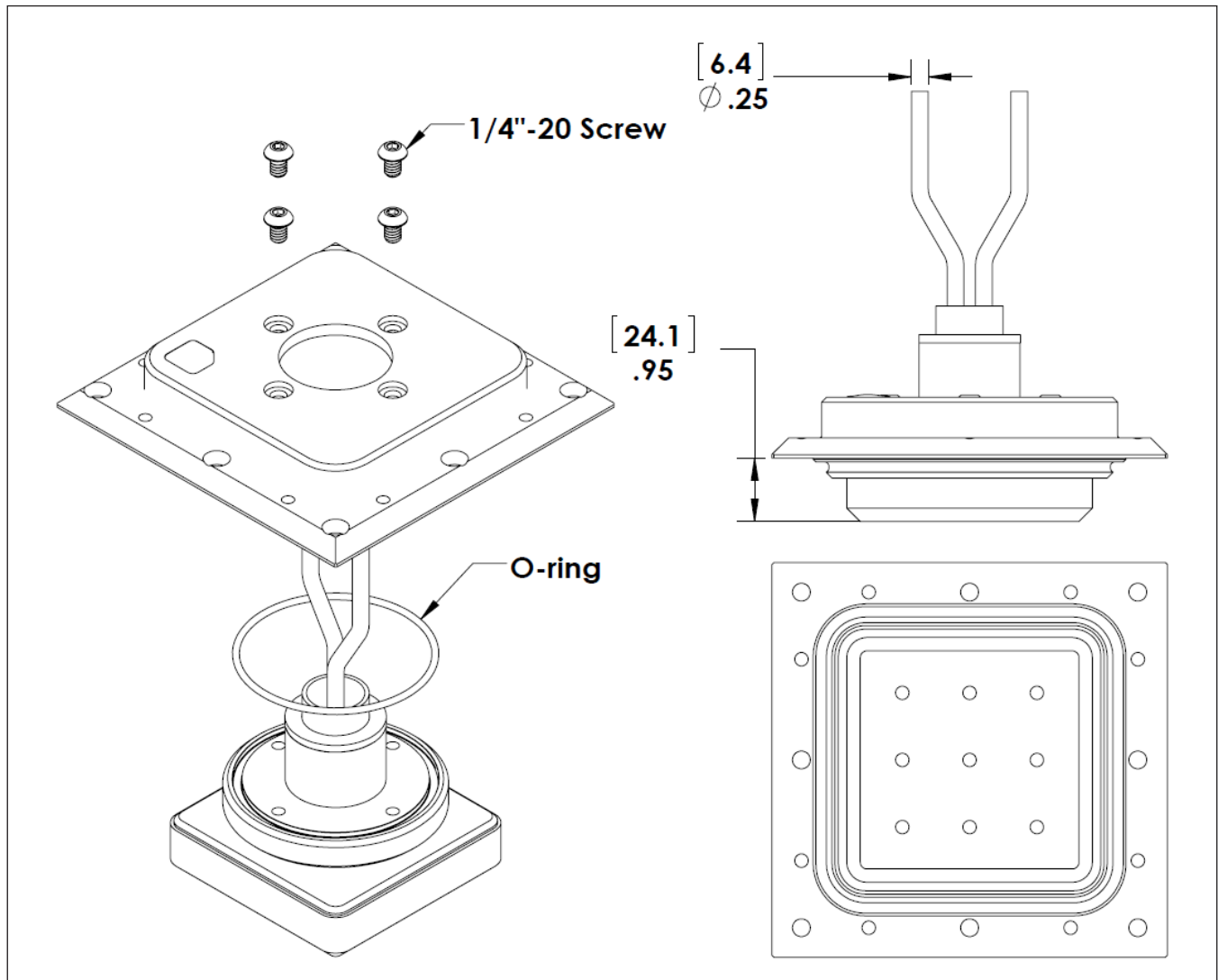

## Vacuum Cube Operation

There are a variety of common methods in the vacuum industry which are used to help a system achieve optimal vacuum performance. These methods and techniques can be applied with great success to your Vacuum Cube chamber. With high-vacuum pumping equipment, a Vacuum Cube system is capable of reaching  $1 \times 10^{-7}$  Torr vacuum pressure.

### System Cleaning

Vacuum Cube Plates come standard with a blue powder coat finish on external faces. Powder coated surfaces are durable and scratch resistant, and can be cleaned with a damp cloth. It is not recommended to use any abrasive materials to clean Vacuum Cube components.

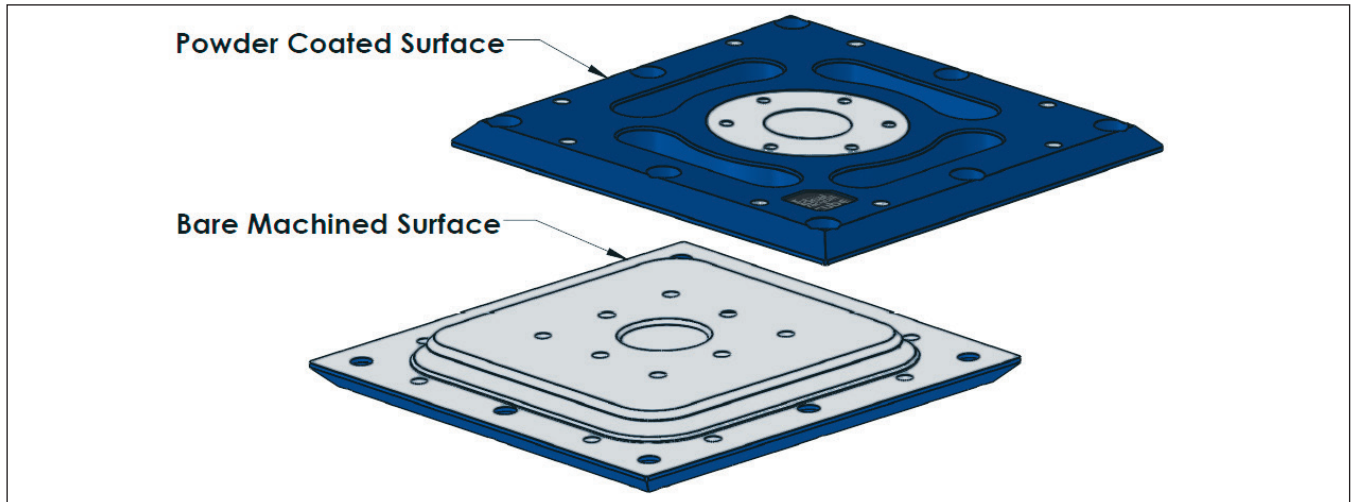

Surfaces which are exposed to vacuum have their original machined finish to minimize chamber outgassing. Contact with these areas should be avoided in order to decrease contamination. It is best to wear gloves when cleaning Cube components. Do not touch vacuum surfaces (surfaces without blue powder coat) with bare hands.

When assembling a Vacuum Cube system, be sure to wipe all vacuum surfaces down with clean, lint-free wipes. A solvent such as Isopropyl Alcohol (IPA) or Methanol can be used to remove residue or other contamination. If water is used to clean vacuum surfaces, it is important to thoroughly dry components before use. (See Baking)

### Baking

It is permissible to bake Vacuum Cube components in vacuum oven prior to assembly. This process will pre-outgas the components and improve chamber pumping speed. For best results immediately assemble the Vacuum Cube and pump down the system following a bake cycle.

The Vacuum Cube system can also be baked during pumpdown in order to quickly achieve ultimate vacuum pressure. The maximum recommended baking temperature for degassing or during operation is 300°F (150°C). If higher baking temperatures are required, please contact Ideal Vacuum Products for information on high-temperature Vacuum Cube accessories.



#### WARNING

Hot surfaces can cause serious burns. Please use caution when baking vacuum cube components.



Be cautious when baking, high temperatures may be present. Gloves and safety glasses should be worn at all times.

## Rough Vacuum

For a single cell Vacuum Cube system, a 2-4 CFM roughing vacuum pump will achieve good pump down performance. Typically a single Vacuum Cube can reach the ultimate pressure of its rough pump within a few minutes. (See “Pumping Curves”) Refer to the table below for a list of suggested vacuum pumps for the Vacuum Cube system.

### Recommended Rough Vacuum Pumps

Brand	Model	Type	Pumping Speed (CFM)	Ultimate Pressure (mTorr)
Agilent	IDP-3	Dry Scroll	2.1	250
Agilent	SH-110	Dry Scroll	4.0	50
Agilent	DS-42	Rotary Vane	1.2	3
Agilent	DS-102	Rotary Vane	3.5	1
Edwards	NXDS-6i	Dry Scroll	4.0	7
Edwards	E2M0.7	Rotary Vane	0.65	3
Edwards	E2M1.5	Rotary Vane	1.2	3
Edwards	RV3	Rotary Vane	2.6	2
Leybold	SC5D	Dry Scroll	3.8	20
Leybold	Trivac D4B	Rotary Vane	3	1
Pfeiffer	ACP 15	Dry Roots	8.5	22.5
Pfeiffer	DUO 3	Rotary Vane	2.5	3

Single Ideal Vacuum Cube, 6x6x6 Inch, Aluminum

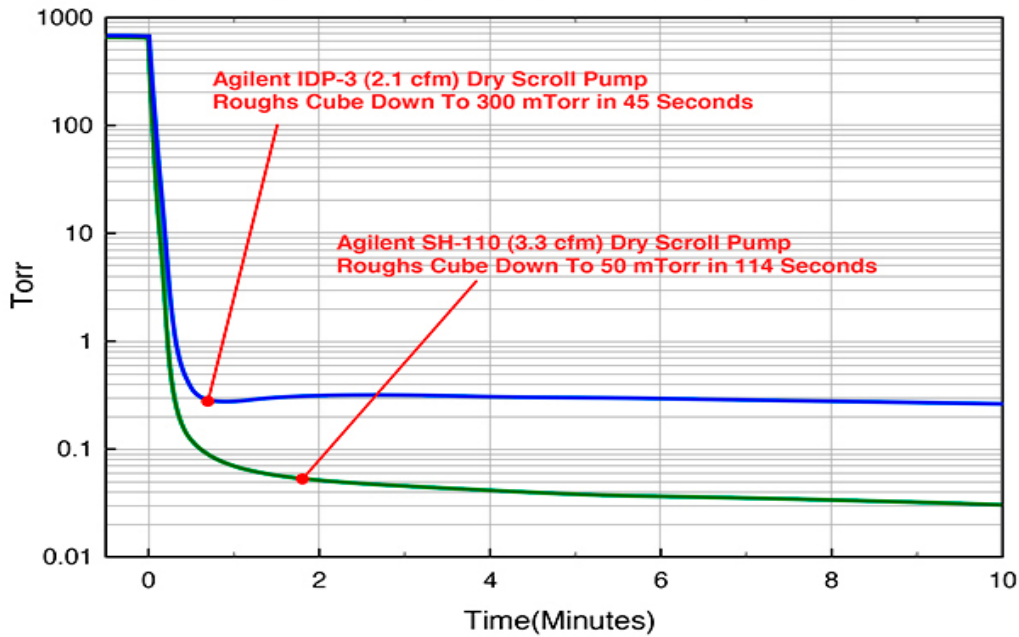

## High Vacuum

When high vacuum is needed, a roughing pump should be augmented with a turbo-molecular pump. An 80 L/s turbo pump pairs well with the Vacuum Cube to easily reach pressures down to  $5 \times 10^{-7}$  Torr. (See “Pumping Curves”)

### Recommended Turbo Molecular Pumps

Brand	Model	Pumping Speed
Pfeiffer	HiPace 80	60 l/s
Agilent	TwisTorr 84-FS	53 l/s
Edwards	EXT 75DX	61 l/s
Leybold	TurboVac TMP 50	55 l/s

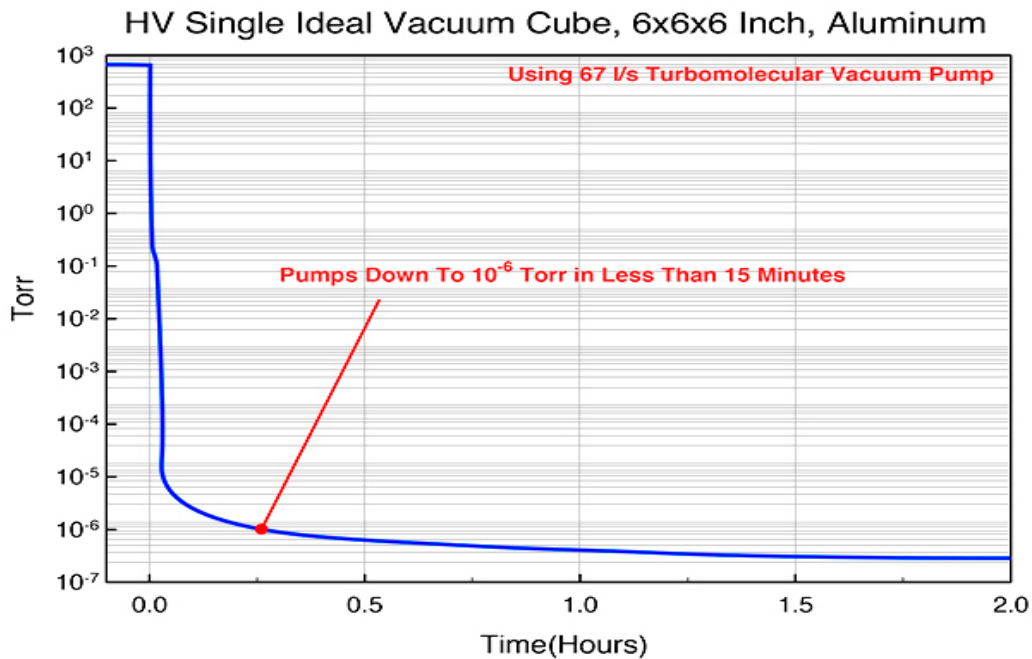

# Ordering List

## 6x6 Plates

REFERENCE	DESCRIPTION	PART No.
2	6x6 Vacuum Cube Chamber Plate With One Each KF-25 Pumping or Feedthrough Port	P106865
3	6x6 Vacuum Cube Chamber, Glass Viewing Window, Plate Assembly	P106869
9	6x6 Vacuum Cube Chamber Plate With One Each KF-40 Pumping or Feedthrough Port	P106863
10	6x6 Vacuum Cube Chamber Plate With 4 KF-16 Pumping or Feedthrough Ports	P106866
15	6x6 Vacuum Cube Chamber Blank Plate, Without Flanged Ports, 6061 Aluminum Alloy	P106862
20	6x6 Vacuum Cube Chamber Plate With One Each ISO-63 Pumping or Feedthrough Port	P106864
23	6x6 Vac. Cube Chamber, Liquid Nitrogen LN2 High Vac. Pumping Trap Cryogenic Fixture	P107301
24	6x6 Vacuum Cube Chamber Plate With One Each KF-50 Pumping or Feedthrough Port	P107296
25	6x6 Vac. Cube Chamber Plate With One Each CF 2.75 in. Pumping or Feedthrough Port	P107298
26	6x6 Vac. Cube Chamber Plate With One Each CF 3.375 in. Pumping or Feedthrough Port	P107299
27	6x6 Vac. Chamber Plate With One Each CF 4.75 in. Pumping or Feedthrough Port	P107300
28	6x6 Vac. Cube Chamber, Thermal Vac. Test Fixture for Cooled or Heated Vac Instrument	P107302

## Accessories

REFERENCE	DESCRIPTION	PART No.
14	6x6x6 In. Vacuum Chamber Frame Only, 6061 Aluminum Alloy	P106861
4	Hinge Assembly & Hardware. Turns Any Plate Into a Door on 6x6x6 Vacuum Cube	P106868
5,6,13,17	Multicube Inner Connection Coupling Kit for 6x6x6 Vacuum Cubes, Inc. Hardware & Seals	P106870
5,6	Multicube Vacuum Tight Coupling Connector, For Joining Two 6x6x6 Vacuum Cube Ends	P106867
17	Multicube Connecting Hardware, Inner Frame Connector, Includes Nut & Washer	P107292
13	Replacement Viton Sealing O-ring, Designed For Sealing 6x6 Vacuum Cube Plates	P107295
13,16	Hardware Kit, Viton O-rings & Plate Bolts, For 6x6x6 Vacuum Cubes Plates	P107293
13,16	Hardware Kit, High-Temperature & Chemical-Resistant, O-rings & Plate Bolts, for 6x6 Plates	P107294
21	Rubber Vibration Support Feet Kit, Designed to Thread Into Any Plate for 6x6x6 Cube	P107297
19	ISO-63 Centering Ring, Aluminum with Viton O-ring	P101766
18	Single Claw Clamp, Metric 8x35L Bolt, for ISO-63 Port	P101786
1	KF-25 Bulkhead Clamp	P104599
12	KF-25 Centering Viton O-ring	P101242
7	KF-40 Bulkhead Clamp	P104600
8	KF-16 Centering Viton O-ring	P101243
11	KF-16 Bulkhead Clamp	P104598

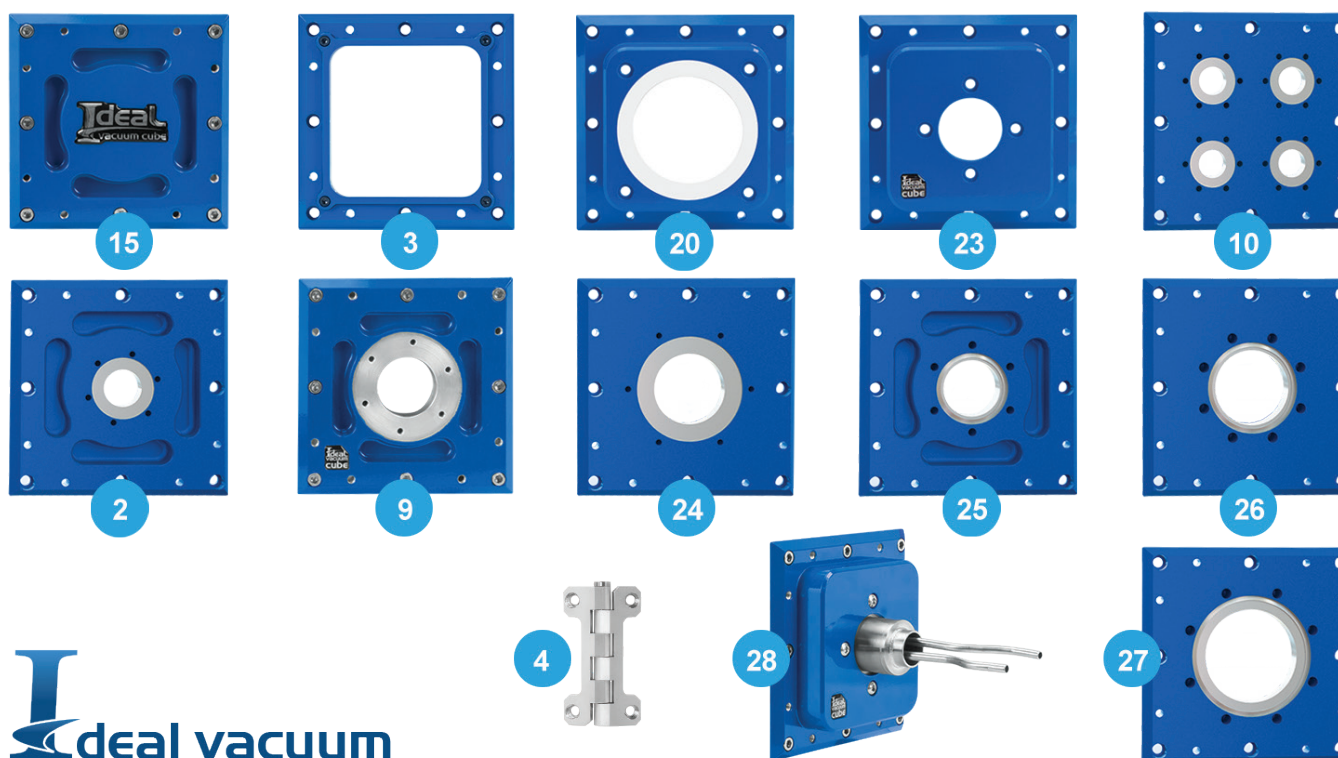

# Stack 6x6x6 Exploded View

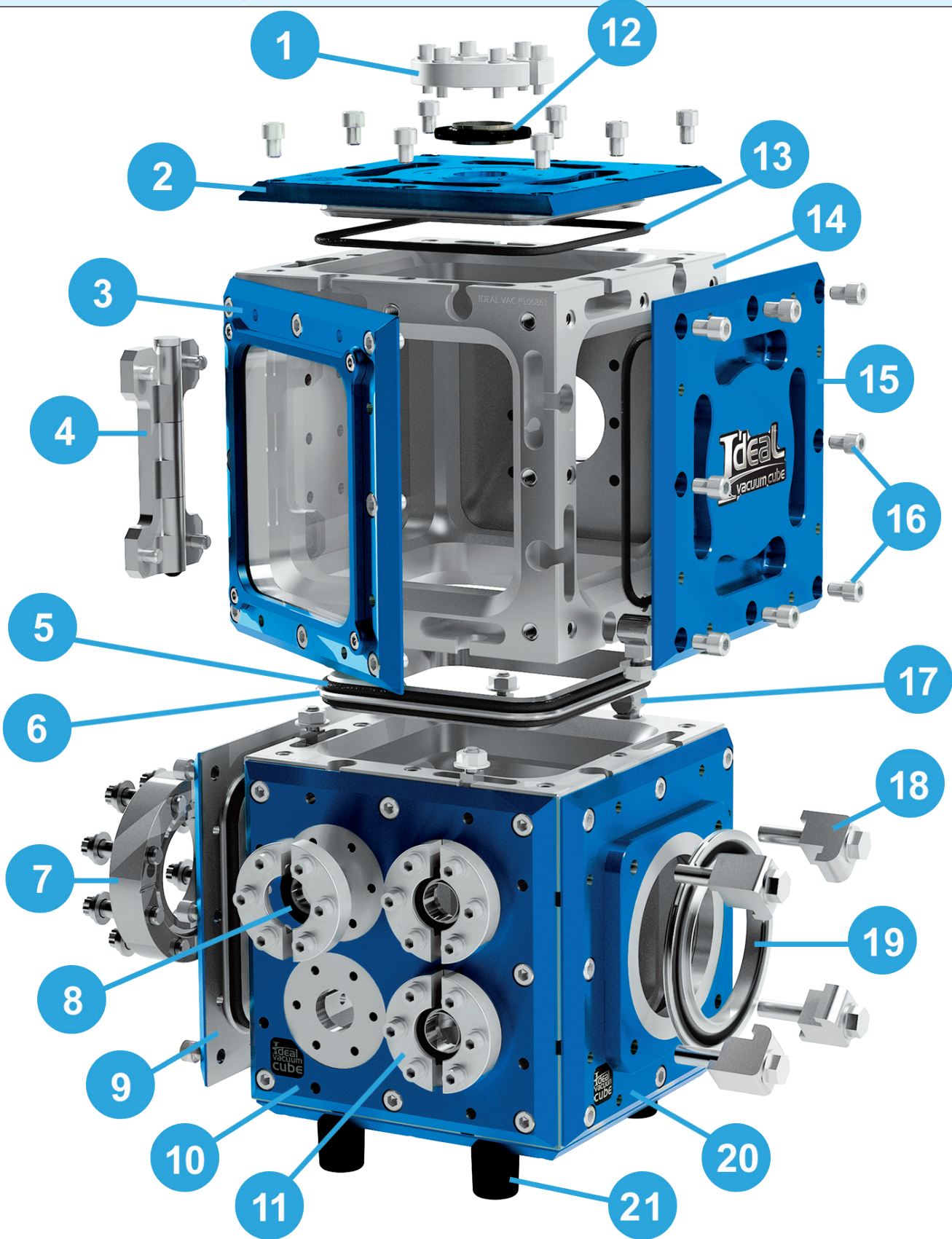

Ideal Vacuum  
5910 Midway Park Blvd. NE  
Albuquerque, NM 87109

(505) 872-0037  
[www.idealvac.com](http://www.idealvac.com)